



**MTHE**  
ELECTRIC TRAINS®

**2008** volume **2**  
RailKing & Premier O Gauge Model Trains

# What We've Been Up To

The first time you open this catalog, we know you'll probably skip this intro and fast forward to see what's new. But when you have a moment, we hope you'll read this page to get the big picture of what we've been up to, throughout our product lines.

## Competitive Pricing



With the economy going through a rough patch, we know it's harder to find those discretionary dollars to spend on trains. We've tried to recognize that by holding the line on prices as much as possible and giving you more features for your money than any other O gauge manufacturer. Yes, some prices have increased modestly. But many engines and cars in this catalog are the same prices they've been for the past few years, and all retain their value-rich features. In the Premier line, for example, you can still buy an A-B-A diesel set with four motors and two smoke units for \$700, considerably lower than our competitors. As in past catalogs, we're also offering selected Premier freight and passenger sets for only \$100 more than the price of the locomotive. In the RailKing line, virtually all of our steam and diesel engines are the same prices they've been for some time. And the deal of the year, in



our view, is the new RailKing® SD70ACe diesel for \$300 with the same Proto-Sound® 2.0 system found in its larger Premier sibling, or \$230 with horn and bell. Look in our train set catalog and you'll also find RailKing SD70ACe sets with cars, track, and 100-watt transformer for only \$80 more than the price of the engine!

## Premier Passenger Cars



If you haven't seen a Premier passenger car in the flesh lately, take another look. We've upgraded the detail level, populated the interiors, and redesigned our trucks with details worthy of an expensive brass model. No, we don't offer scale-length 21" cars; some of our competitors are doing a great job in that area. But we do think we offer the best 17½" scale-detailed cars you can buy, and a majority of our customers tell us that length is a great compromise for the size of their layouts and the radius of their curves. Even on large O-72 curves, a train of 17½" cars flows better and, one might argue, looks more like a real passenger train. And our Premier cars are still selling for \$80 to \$90 per car — so in many cases a full M.T.H. passenger train costs hundreds less than a train from our competitors.

## Premier Freight Cars



Take another look at our freight cars, too. Throughout the Premier freight line, we've ramped up the realism with more added-on detail parts. Our newest tooling has a detail level comparable with anything else in the hobby,

and still offers the smooth-operating trucks and couplers and the durability you want in a model intended for operation — not just display. Our modern 60' TTX flatcar, for example, comes with optional tie-down chains and load adjusters that you can install for more realism.

## European Models



In the last catalog, we introduced a Premier French Pacific, our first European engine. The enthusiastic response from European customers and dealers has led us to expand the European lineup to four engines and a set of passenger cars in this catalog. Does this mean

we're paying less attention to American prototypes?

Absolutely not. What it means for U.S. customers is some exciting new models to



choose from, and the opportunity to spread our development costs over a wider customer base — which means more resources to come up with new features for all of our product lines. As an example, our expansion into the HO market has led us to develop smaller electronics packages that will eventually find their way into smaller, more realistic tenders for some O gauge steamers.

On the other side of the Pond, O gauge models are built to slightly different and slightly larger scales: 1:43.5 in England and France and 1:45 in the rest of Europe, com-





pared to the 1:48 scale of American O Gauge. To ensure compatibility with existing European models, our European models will be built to the correct scales for their respective countries and delivered with both American and European couplers. Many European railroads, particularly in Britain, have a smaller maximum height than American railroads, so 1:43.5, 1:45 and 1:48 models will look and run fine with each other



### DCS™ 4.0

As you may already know, this past March we released DCS 4.0, the latest software upgrade for the M.T.H. Digital Command System. Among other features, 4.0 offers improved control of Proto-Sound 2.0 engines and full emulation of virtually every feature of the Lionel® CAB-1® handheld controller. To learn more, go to [www.protosound2.com](http://www.protosound2.com) and download the DCS 4.0 instruction manual. As always, this upgrade is available for free over the Internet and is compatible with every DCS system ever made.

If you haven't tried DCS and are running your trains in conventional mode, consider this: For the price of one RailKing locomotive, you can own a DCS system that opens up new features for every single Proto-Sound 2.0 engine on your railroad.

### What's new in this catalog

As always, this catalog announces new models we've never offered before, upgrades of previous models, and paint schemes appearing for the first time in O scale. In the

RailKing line, you'll find several steam locomotives upgraded to Imperial models with additional detailing at no additional cost, including the Pennsy Decapod, offered with either a long or short tender, and the huge C&O Allegheny. In addition to the SD70ACe mentioned earlier, the stylish F59PHI joins the Imperial diesel line.



A unique Camelback steamer joins the Premier line for the first time; other new tooling includes a pair of engines known for their muscle, the 3600 hp SD45 diesel in Great Northern "Hustle Muscle" and other road names, and the Princess Coronation Pacific, the most powerful steam engine ever to serve in England. Our super-detailed Premier SD70ACe returns in one of the most colorful modern paint schemes, the Kansas City Southern. Also offered is the EMD E8 diesel as restored in polished Pennsy colors by businessman Bennett Levin and seen frequently today on northeastern rails. For subway fans, there's the Train of the Future of 1949, New York's R-11.

If you haven't already, we invite you now to turn the page and see for yourself what we have to offer. As always, we hope you'll find items in this catalog that will surprise and delight you, and help you continue to enjoy this most wonderful of hobbies.



[www.mthtrains.com](http://www.mthtrains.com)



## Table of Contents

<b>Proto-Sound® 2.0</b>	2
<b>DCS</b>	4
<b>RailKing</b>	6
R-T-R Sets	8
Steam	10
Diesel	22
Transit	38
Freight	40
Passenger Cars	66
<b>Premier</b>	70
Steam	72
Diesel	88
Electric	108
Transit	118
Freight	122
Passenger Cars	152
<b>M.T.H. HO</b>	160
<b>Transformers</b>	162
<b>ScaleTrax™</b>	164
<b>Accessories</b>	170
<b>M.T.H. RailRoders Club</b>	174
<b>Mega Stations</b>	176
<b>MTH Online</b>	177

To receive the latest updates on catalog items, sign up for our weekly e-newsletter. Go to the News link at the top of our home page,

[www.mthtrains.com](http://www.mthtrains.com).

# Proto-Sound® 2.0...

THE RICHEST SET OF FEATURES IN MODEL RAILROADING!

Whether you operate with a conventional transformer or in command mode with DCS (M.T.H.'s Digital Command System), the Proto-Sound 2.0 system found in every locomotive in this catalog offers more realism, more fun, and more variety than any other locomotive control system in any scale.



## VIVID ENGINE SOUNDS

Proto-Sound features digital recordings with CD-quality playback. We strive to make our sounds as authentic as possible, using the characteristic whistle for a particular steam engine, for example, and the correct prime mover sound for each manufacturer's diesels. With the optional DCS system, you can tune each engine to your preference by individually adjusting bell, horn or whistle, and chuff or diesel motor volume.

## STATION SOUNDS

Proto-Sound passenger engines offer Passenger Station Proto-Effects™, a complete arrival and departure sequence

that you can activate from your transformer or DCS handheld. In most cases, the station sequence features an actual name train pulled by that particular engine. Freight engines include Freight Yard Proto-Effects, a symphony of freight terminal sounds.

## ATMOSPHERIC SOUNDS

Crew conversations, the whoosh of a steam engine opening its cylinder cocks, and a host of other atmospheric sounds play automatically at random when using a conventional transformer - or can be activated manually from the DCS handheld.

## EXTRAORDINARY SLOW SPEED CAPABILITY

Proto-Sound engines can throttle down as slow as three scale miles per hour, highball down the main line, and maintain any speed in between. In DCS mode you can set engine speed in one-scale-mile-per-hour increments up to 120 smph. Go ahead, get out your stop watch and ruler and see how accurate our scale speeds are.

## SPEED CONTROL

The Proto-Speed Control™ built into Proto-Sound 2.0 acts like the cruise control on a car, keeping your train moving at the speed you select, regardless of hills and curves. You can even switch off the speed control if you prefer.

## MULTIPLE UNIT CAPABILITY

In DCS command mode, all locomotives set to the same speed - 37 scale miles per hour, for example - will move at virtually the same speed. This makes it easy to double or even triple-head nearly any combination of Proto-Sound 2.0 locomotives.

## LIGHTING EFFECTS

Proto-Sound locomotives feature a variety of prototypical lighting effects. Depending on the locomotive, these may include constant-brightness headlights, illuminated number boards, marker lamps, firebox glow in many steam locomotives, and operating Mars lights or oscillating ditch lights (where appropriate) on diesels. In DCS operation, many of these lighting effects can be individually controlled.

## GREAT SMOKE

Proto-Sound steam engines and diesels feature fan-driven ProtoSmoke™, the most powerful smoke system in the hobby. You can vary the intensity with the smoke "volume" control on the locomotive or remotely with a DCS handheld.

## SYNCHRONIZED CHUFF AND PUFF

Like a real steam engine, M.T.H. steamers feature puffs of smoke and steam chuff sounds synchronized with the drive wheels. Better than any other model train, an M.T.H. locomotive portrays the drama of a steam engine slowly chuffing and puffing as it pulls out of a station and gets up to speed. Even our diesels feature incremental smoke output based on speed, just like the real thing!

## BRAKE SOUNDS

Engine brakes squeal whenever you throttle back sharply or pull into a station. In DCS mode, you can trigger the brake sound with the Brake button on the DCS handheld.

## REMOTE UNCOUPLING

Proto-Sound steam and diesel engines offer remote uncoupling anywhere on your layout, controlled from your transformer or DCS remote. The opening of the coupler is accompanied by the hiss of air hoses parting and the clank of the coupler knuckle opening.

## COMMAND CONTROL

Add the M.T.H. Digital Command System (DCS) to your railroad and enjoy the command control capability built into every Proto-Sound 2.0 locomotive. Operate up to 99 engines on the same track at the same time with individual control over each engine. For more information on command control and DCS, see the next page or go to [www.protosound2.com](http://www.protosound2.com).

## UPDATED ENGINE FEATURES

Using a DCS system, any Proto-Sound 2.0 engine can be updated with new sounds or features without ever taking the engine apart or even off the track. Simple downloads of new Proto-Sound sound sets from the M.T.H. website mean your engine will never be obsolete. It can change from a passenger train to a freight train or get a new whistle or horn in just minutes.

## BI-DIRECTIONAL COMMUNICATION

Proto-Sound 2.0 engines not only receive commands from the DCS system, they can report back vital information, trigger other devices to operate and diagnose your model railroad layout's wiring and signal quality. Imagine quering a Proto-Sound 2.0 locomotive to find out how many scale miles its run or how many hours it's been powered up. How about checking out the strength of the DCS signal on the track or measuring the track voltage at a trouble spot? What about learning how long your track is in scale miles? All of this is possible today, but only in a Proto-Sound 2.0 equipped locomotive when operated using the DCS Digital Command System.

## About Our Product Lines

In this catalog you'll find three of the five M.T.H. product lines, our O Gauge Premier and RailKing lines and a new offering from our HO line. While they differ in detail level and price, under the shell they're very much the same. Every engine in this catalog shares the same Proto-Sound 2.0 or later electronics and the same quality M.T.H. construction. Premier, RailKing HO Gauge engines can be run together on your railroad in conventional or DCS command mode.

**Premier** engines are full O scale models, 1/48 the size of their prototypes. Because of this, they often require larger radius curves than comparable RailKing models. Premier engines are as detailed as we can reasonably make them, and feature a large number of added-on parts. On Premier steamers, for example, most piping is separately applied, whereas piping on RailKing steam engines is cast onto the boiler. While smoke is standard on virtually all M.T.H. steamers, only Premier and RailKing Scale and Imperial diesels feature smoke. Premier engines also have more elaborate lighting effects.

**RailKing** models have less detail and are lower priced than their Premier counterparts. Unless otherwise noted, all RailKing engines will negotiate O-31 curves. While RailKing Scale engines are full O scale size, other RailKing engines may have smaller proportions than their prototypes, to make them appropriate for smaller traditional layouts with O-31 curves. RailKing Imperial models are our top-of-the-line RailKing engines, with features such as real coal loads and separately illuminated marker lamps.

**RailKing One Gauge** equipment offers long-lasting, impact-resistant polycarbonate bodies, powerful flywheel-equipped DC can motors, and precise 1:32 scale proportions and detail. Features include metal handrails, spinning fans, constant voltage lighting, puffing smoke timed to the engine's chuffing, firebox glow, cab figures, sliding cab windows, and much, much more. In addition to the eye-popping detail, the line is built tough for years of outdoor operation.

**Tinplate Traditions™** models are made of stamped or die-cast metal, generally boasting bright, colorful enamel paint and M.T.H.'s state-of-the-art digital electronics. Unlike Premier and RailKing models, these are not meant to be accurate reproductions of real trains yet provide collectors who cannot afford a pre-World War II original access to faithful, high quality, and highly detailed reproductions of model railroading's most nostalgic era.

The **M.T.H. HO** product line is our newest venture and is infused with locomotives sporting the absolute latest in cutting-edge digital electronics for the HO market. The GS4 Northern locomotives are the second of several all-new releases slated for 2008.

**DCS**<sup>TM</sup>  
BY MTH ELECTRIC TRAINS  
DIGITAL COMMAND SYSTEM

# SIMPLY T TO RUN

THIS REMOTE IS **SIMPLE**.

IT SPEAKS **ENGLISH,**  
**NOT ICONS.**

IT CAN BE **OPERATED**  
**EASILY WITH ONE**  
**HAND.**

IT CAN BE  
**UPGRADED FOR**  
**FREE** OVER THE  
INTERNET.

It can run 900\* Proto-Sound® 2.0 engines and every Lionel®, Atlas, Weaver, and Third Rail TMCC®, EOB, or Legacy™ engine ever made — and run 99 of them at the same time, on the same track, independently, in command mode.

It can also **RUN ALL CONVENTIONAL AC LOCOMOTIVES** without the purchase of any additional hardware.

With the addition of an Accessory Interface Unit (AIU), it can **OPERATE ANY O SCALE ACCESSORY OR SWITCH.** It can create scenes and routes that are triggered with one push of a button.

## WHAT CAN YOUR REMOTE DO?



\* Number of different Proto-Sound® 2.0 engines cataloged through the 2008 Volume 2 MTH catalog.

While all TMCC features can be accessed by the DCS handheld remote, at present some Legacy features cannot be accessed by the DCS remote.

# THE BEST WAY A RAILROAD™

## Command Control Explained

In conventional operation, an AC or DC transformer varies track voltage to adjust engine speed and direction. Command systems such as DCS, however, put a constant voltage on the track (around 18 volts for DCS) and vary speed by telling each engine how much of that voltage to use. Command control allows different engines to do different things — like run at different speeds, go in different directions, or make different sounds — even when they are on the same track.

In the DCS system, commands such as speed, direction, and sound control are sent as radio signals from the handheld throttle to a TIU (track interface unit). The TIU translates those radio signals into digital information that is sent through the rails and picked up by a receiver in the appropriate engine —

telling it to go, for example, 37 miles per hour, blow the whistle, smoke more heavily, or any other command. DCS locomotives can also send information back to the handheld to let the operator know what they're doing.

A unique feature of DCS is the ability to control the other major command systems used by 3-rail O gauge modelers, Lionel's TrainMaster® Command Control (TMCC®) and Legacy™ systems. With the addition of a Lionel command base, the DCS handheld can control engines from all systems on the same track at the same time.

The new TIU/TMCC-Legacy Connector Cable also allows you to run both the DCS and Legacy systems simultaneously on your layout, using both the DCS and Legacy handheld remotes.

## New! DCS 4.0

DCS 4.0, the latest DCS software upgrade, is now available as a free download and is fully compatible with all DCS systems and every Proto-Sound 2.0 engine ever made. DCS 4.0 features new engine control options; allows the DCS handheld to emulate virtually every feature of the TMCC CAB-1® handheld; and allows the user to back up data on the DCS handheld to a personal computer — and clone that data to another DCS handheld if desired.

For more information on DCS 4.0 and the entire DCS system, go to [www.protosound2.com](http://www.protosound2.com)

**INTUITIVE MENUS** ALLOW YOU TO **PROGRAM, SELECT, AND CONTROL ENGINES, SWITCHES, AND ACCESSORIES.**

**1** Go to the engine setup menu

```
▶ ADD ENGINE
  EDIT ENGINE
  DELETE ENGINE
  MENU:ENGINE SETUP
```

**2** Choose your engine type

```
▶ ADD MTH ENGINE
  ADD TMCC ENGINE
  MENU:ADD ENGINE
```

**3** DCS will "look" for Proto-Sound® or TMCC command-equipped engines on your layout. When it finds one, it adds it onto your remote and tells you when it's done.

```
CONGRATULATIONS
YOU SUCCESSFULLY
ADDED AN MTH ENGINE
```

```
SMPH: 10
1: PRR S1
MTC SCS S01 LIN →
```

\*TMCC operation requires a TMCC command base & DCS TIU/TMCC cable

DCS Remote Control System  
50-1001 \$299.95

DCS Remote Control -  
Handheld Unit  
50-1002 \$149.95



DCS Track Interface Unit (TIU)  
50-1003 \$179.95



DCS Accessory Interface Unit (AIU)  
50-1004 \$99.95

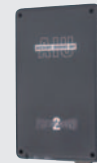

DCS Commander Controller  
50-1028 \$149.95

DCS Commander System w/100 Watt  
Power Supply  
50-1029 \$229.95



TIU/TMCC-Legacy 6' Connector Cable  
50-1032 \$19.95

**NEW!**



6' Mini-to-Mini Cable  
50-1009 \$9.95



Proto-Sound 2.0 Battery Charger  
50-1019 \$14.95

TIU/Barrel Jack Adapter Cable  
50-1017 \$9.95



TIU/TMCC 6' Connector Cable  
50-1018 \$19.95

Proto-Sound Battery  
50-1008 \$9.95



AA NiCad Proto-Sound® Battery  
50-1024 \$9.95

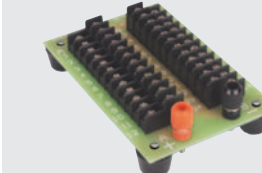

24-Port Terminal Block  
50-1020 \$29.95

12-Port Terminal Block  
50-1014 \$19.95



Video Guide To DCS - DVD  
60-1191 \$19.95

# Introduce a Friend —or a Child —to Model Railroading with an M.T.H. Train Set



M.T.H. trains are **MORE FUN** because they portray the sights and sounds that make real trains dramatic and exciting.



## GREAT SMOKE

Our steam engines feature fan-driven ProtoSmoke, the most powerful smoke system in the hobby.

## SPEED CONTROL

Many toy trains have two speeds: fast and faster. Most M.T.H. locomotives feature Proto-Sound 2.0, our unique sound and control system that allows our engines to throttle down to a slow crawl, highball down the main line, or maintain any speed in between. The Proto-Speed Control built into Proto-Sound 2.0 acts like the cruise control on a car, keeping your train moving at the speed you select, regardless of hills and curves.

## VIVID ENGINE SOUNDS

Proto-Sound features digital recordings with CD-quality playback: the wail of a diesel horn; the melody of an authentic steam whistle; the bell alerting passengers to your arrival or departure; and diesel roar or steam chuff that vary automatically depending on how hard your engine is working.

## SYNCHRONIZED CHUFF AND PUFF

Like a real steam engine, M.T.H. steamers feature puffs of smoke and steam chuff sounds synchronized with the drive wheels. Better than any other toy train, an M.T.H. locomotive portrays the drama of a steam engine s-l-o-w-l-y chuffing and puffing as it pulls out of a station and gets up to speed.



## STATION SOUNDS

Proto-Sound passenger engines offer Passenger Station Proto-Effects, a complete arrival and departure sequence that you can activate from your transformer. Freight engines include Freight Yard Proto-Effects, a symphony of freight terminal sounds.

## REMOTE UNCOUPLING



Proto-Sound steam and diesel engines offer remote uncoupling anywhere on your layout, accompanied by the clank of the coupler opening and the hiss of air hoses parting.



## O GAUGE IS MORE FUN



Model trains come in a variety of sizes. Smaller sizes such as HO gauge and N gauge allow hobbyists to fit a lot of highly detailed railroad into less space. But we think O gauge — the traditional size for train sets for more than half a century — is the perfect size for a child's first electric train. Judging by the rising popularity of O gauge over the past two decades, it has become the perfect size for many adults as well. Standing about twice the size of HO trains, O gauge trains are more fun because:

### **They stay on the track:**

O gauge trains hold the track better at the high speeds that children often prefer, thanks in part to the larger flanges on O gauge wheels.

### **They're easy to handle:**

The larger size of O gauge trains makes them easier for children to

handle than smaller-gauge trains — and much easier to place on the track. Large-size operating knuckle couplers make O gauge trains easy to couple and uncouple, and more fun to play with.

**They're impressive:** Size and weight make an O gauge train a memorable toy. M.T.H. steam engines feature die-cast metal boilers and frames, M.T.H. diesels and cars feature die-cast metal trucks, and all M.T.H. products have metal wheels and couplers. If you're looking for a toy that will make a long-term impression on a child, it's hard to beat an O gauge train.

**They do things:** O gauge offers a variety of operating, animated cars and accessories that is unmatched by any other scale or gauge.

# THE HIGHEST QUALITY TRAIN SETS YOU CAN BUY



*Every RailKing passenger car has a detailed, lighted interior and die-cast metal trucks and couplers.*

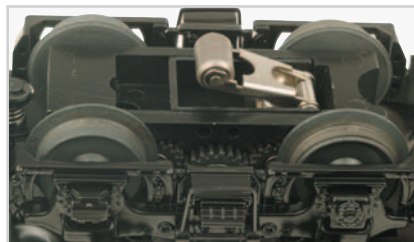

*Every RailKing locomotive features durable metal gears, wheels, axles, and couplers.*



*Every RailKing Freight car features die-cast metal trucks and couplers, with hidden uncoupling plates (not old-fashioned "thumbtacks")*

At M.T.H., we consider the ready-to-run train set our best opportunity to make a great impression on any newcomer to the wonderful world of model railroading. That's why we don't skimp on the quality and value you'll find in every RailKing and Tinplate Traditions ready-to-run starter set. Compare our sets with those of our competitors and you'll see what makes an M.T.H. starter set the best way to begin your model railroading journey.

Every RailKing O Gauge ready-to-run set features RealTrax®, O Gauge's first and most complete line of snap-together track with built-in roadbed. Only RealTrax features filled metal track rails instead of cheaper hollow rails that can bend if stepped on. See the complete RealTrax line in our Ready-to-Run Catalog.

Every 2008 M.T.H. Train set also features a U.L. approved transformer to ensure that your set has enough power now and when you expand it with extra cars, track and accessories.

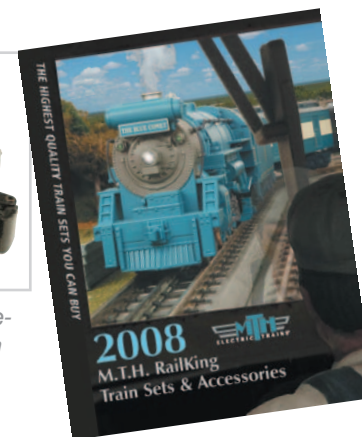

**See More  
in the  
2008  
Ready-To-Run  
Catalog!**



## 2-8-0 STEAM R-T-R SETS



### Features

#### Set Features:

- Die-Cast Steam Locomotive
- 3-Car Freight Consist
- RailWare™ Interactive DVD With Track Layout Software
- 31" x 51" 12-Piece RealTrax® Oval
- Z-1000™ Transformer With Controller
- Lighted Track Lock-On

#### Locomotive Features:

- Die-Cast Boiler and Chassis
- Flywheel Equipped Motor
- Locomotive Speed Control
- Electronic Reverse Unit
- Operating Metal Coupler
- Operating Headlight
- Synchronized Puffing ProtoSmoke™ Unit
- All-Metal Wheels and Gears

- Proto-Sound® 2.0 with Freight Yard Sounds or Loco-Sound™ Sound System with Chuffing Steam, Whistle and Bell Sounds
- Locomotive Measures: 19 1/4" x 2 1/2" x 3 3/4"

#### Freight Cars Feature:

- Intricately Detailed Durable ABS Bodies
- Die-Cast 4-Wheel Trucks
- Metal Wheels and Axles
- Operating Die-Cast Metal Couplers
- Colorful, Attractive Paint Schemes
- Freight Cars Measure: 10 3/4" x 2 3/8" x 3 1/8"

A classic freight set is a great way to start your family's model railroading tradition and the Pennsylvania or New York Central 2-8-0 Consolidation freight set makes a great beginning. Decorated in near-black Pennsylvania Brunswick Green or black NYC colors, this creative adaptation of the 2-8-0 features an all-metal boiler and chassis that feels as strong as it runs. The all-metal gears, wheels and axles will ensure a life-time of fun. Trailing behind the puffing locomotive are three freight cars with sprung die-cast metal trucks and operating metal couplers. As with all RailKing Ready-to-Run sets, the 12 piece RealTrax oval assembles in minutes and can be placed right on the carpet for a quick, temporary layout.



*RailKing Ready-to-Run Train Sets Include Track, Transformer, Interactive DVD with Track Layout Software and Operator's Manual.*



**New York Central** - 2-8-0 Steam Engine  
33-1031-1 w/Proto-Sound 2.0 \$249.95



**Union Pacific** - 2-8-0 Steam Engine  
33-1032-1 w/Proto-Sound 2.0 \$249.95



**Great Northern** - 2-8-0 Steam Engine  
33-1016-1 w/Proto-Sound 2.0 \$249.95



**Pennsylvania** - 2-8-0 Steam Engine  
33-1012-1 w/Proto-Sound 2.0 \$249.95

**See More  
in the  
2008  
Ready-To-Run  
Catalog!**



**Pennsylvania** - 2-8-0 Steam R-T-R Train Set  
30-4136-1 w/ Proto-Sound 2.0 \$329.95  
30-4136-0 w/Loco-Sound \$249.95



**New York Central** - 2-8-0 Steam R-T-R Train Set  
30-4185-1 w/ Proto-Sound 2.0 \$329.95  
30-4185-0 w/Loco-Sound \$249.95

# 0-6-0 USRA STEAM SWITCHER



## Features

- Die-Cast Metal Chassis
- Authentic Paint Scheme
- Metal Wheels and Axles
- (2) Remote Controlled Proto-Couplers™
- Precision Flywheel Equipped Motor
- Metal Handrails and Decorative Bell
- Decorative Metal Whistle
- Die-Cast Boiler and Tender Body
- Constant Voltage Headlight
- Die-Cast Truck Sides
- Operating Tender Back-up Light
- Synchronized Puffing ProtoSmoke® System
- Locomotive Speed Control In Scale MPH Increments
- Engineer and Fireman Figures
- Real Coal Load
- Proto-Sound® 2.0 With The Digital Command System Featuring Freight Yard Proto-Effects™
- Unit Measures: 17 1/2" x 2 7/8" x 3 1/2"
- Operates On O-31 Curves

Switch engines are an essential, specialized piece of railroad equipment that look quite different from their kin that work the mainline. Because of the nature of their work, moving cars around railroad yards, switch engines spent much of their time waiting for their assignments. That means steam switchers needed smaller fireboxes, boilers, and tanks than road engines. The cut out or sloping tanks on most steam switchers were designed to give good rear visibility, which was essential for these small and agile engines that needed to slip into tight spaces where other engines could not fit. The 0-6-0 switcher would typically have been assigned to move about six cars at a time.

The rugged 0-6-0 returns to the RailKing lineup in 2008 in our Imperial Series class and comes outfitted with enhanced details and a real coal load in the all-metal die-cast tender. Available in a host of roadnames, this little switcher is perfect for working the yard of any early twentieth-century layout.

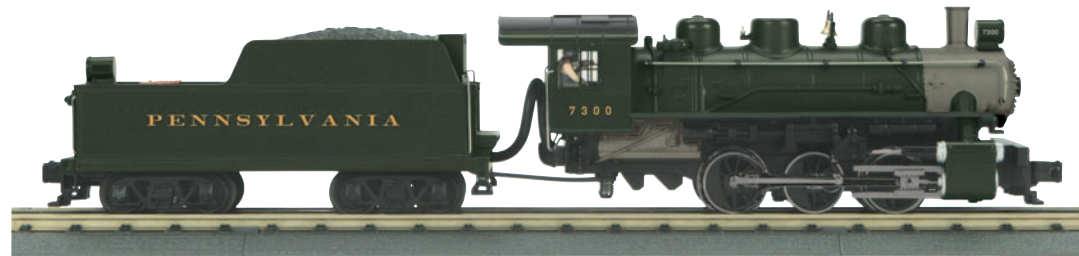

**Pennsylvania** - 0-6-0 USRA Steam Switcher  
30-1499-1 w/Proto-Sound 2.0 \$399.95



**New York Central** - 0-6-0 USRA Steam Switcher  
30-1498-1 w/Proto-Sound 2.0 \$399.95



**Southern** - 0-6-0 USRA Steam Switcher  
30-1500-1 w/Proto-Sound 2.0 \$399.95

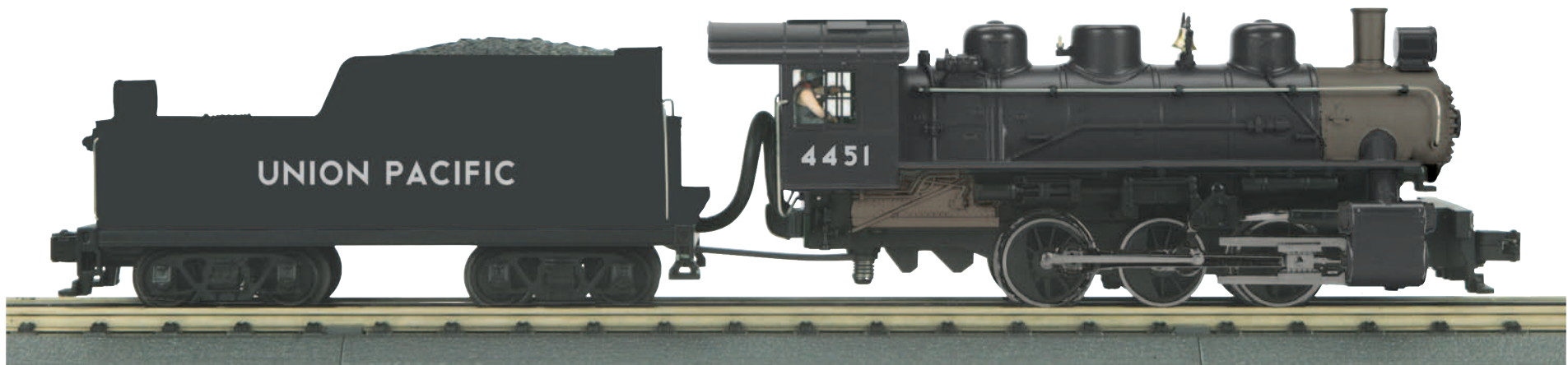

**Union Pacific** - 0-6-0 USRA Steam Switcher  
30-1501-1 w/Proto-Sound 2.0 \$399.95

# 2-10-0 DECAPOD STEAM ENGINE



## Features

- Die-Cast Metal Chassis
- Authentic Paint Scheme
- Metal Wheels and Axles
- Remote Controlled Proto-Coupler™
- Precision Flywheel Equipped Motor
- Metal Handrails and Decorative Bell
- Decorative Metal Whistle
- Die-Cast Boiler and Tender Body
- Constant Voltage Headlight
- Die-Cast Truck Sides
- Operating Tender Back-up Light
- Synchronized Puffing ProtoSmoke™ System
- Locomotive Speed Control In Scale MPH Increments
- Engineer and Fireman Figures
- Real Coal Load
- Proto-Sound® 2.0 With The Digital Command System Featuring Freight Yard Proto-Effects™
- Unit Measures: 21 9/16" x 2 1/2" x 3 3/4"
- Operates On O-31 Curves

By the 1910s, the Pennsylvania Railroad was hauling coal and ore by the tons, and it sought a more efficient way to do so than double-heading 2-8-2 engines. Thus was born the monstrous I Class 2-10-0 Decapod. It dwarfed all previous 2-10-0s, weighing in at 386,100 pounds, with a power output 41% higher and steam consumption 12% lower than the Mikados that were previously assigned to coal and ore duty. Pennsy heartily approved of the new

design and ultimately had the Baldwin and Juniata shops build 598 Class I1s.

These hulking engines were designed specifically for use in the mountainous Allegheny region of western Pennsylvania, and they hauled freight through that area like nothing the PRR had seen before. The typical assignment called for two Decapods at each end of every freight

train, and despite their enormous size and weight, they were allowed to move at up to fifty miles per hour.

M.T.H. is proud to bring the ground-shaking power of the Pennsylvania 2-10-0 to your railroad, available in both a long and short tender.



**Pennsylvania** - 2-10-0 Decapod Steam Engine  
30-1503-1 w/Proto-Sound 2.0 \$429.95



**Pennsylvania** - 2-10-0 Decapod Steam Engine  
30-1502-1 w/Proto-Sound 2.0 \$429.95

# 4-8-2 L-3 MOHAWK STEAM ENGINE

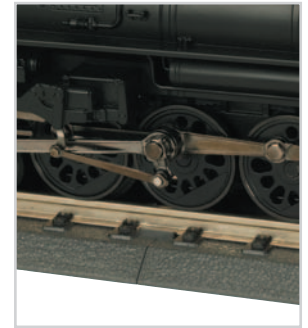

## Features

- Constant Voltage Headlight
- Precision Flywheel Equipped Motor
- Remote Controlled Proto-Coupler
- Metal Handrails and Decorative Bell
- Decorative Metal Whistle
- Synchronized Puffing ProtoSmoke™ System
- Metal Wheels and Axles
- Locomotive Speed Control In Scale MPH Increments
- Die-Cast Boiler and Tender Body
- Engineer and Fireman Figures
- Operating Firebox Glow
- Operating Tender Back-up Light
- Proto-Sound® 2.0 With The Digital Command System Featuring Freight Yard Proto-Effects™
- Unit Measures: 22" x 2 1/2" x 3 1/2"
- Operates On O-31 Curves

To receive the latest updates on catalog items, sign up for our weekly e-newsletter. Go to the News link at the top of our home page,

[www.mthtrains.com](http://www.mthtrains.com).



In 1910, the C&O sought a new type of steam engine to haul passenger trains over the Allegheny Mountains. The result was a new locomotive type that would combine the eight drivers of the Mikado with the four-wheel lead truck of the Pacific. Although the 4-8-2s were initially called "Mountains," the New York Central Railroad felt that name was inappropriate for their flat "Water Level Route." They changed the name to Mohawk in honor of New York's Mohawk River and Valley.

Weighing almost 400,000 pounds, equipped with one of the largest tenders yet (43 tons of coal) and producing tractive force of more than 60,000 pounds, the L-3 Mohawks were versatile enough to do almost any job required of them. The New York Central was so pleased with the performance of L-2s converted to carry passenger trains that in 1940 they ordered 25 specially made L-3a "dual purpose" Mohawks--designed to haul either passenger cars or their usual freight loads.

The Mohawk Steam Engine is a detailed recreation of this versatile engine presented in the livery of five railroads. Each locomotive is equipped with more conventionally operated standard features than offered by any other O Gauge manufacturer.

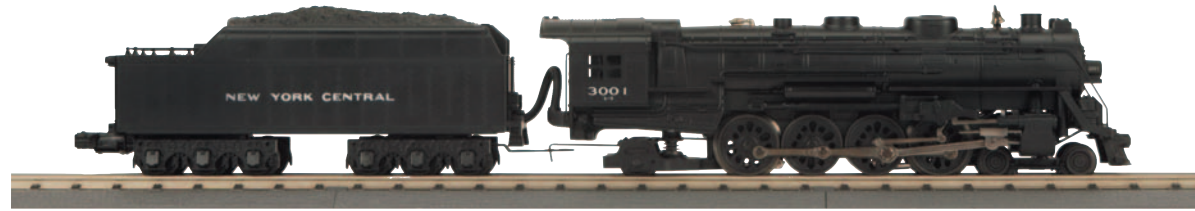

**New York Central** - 4-8-2 L-3 Mohawk Steam Engine  
30-1493-1 w/Proto-Sound 2.0 \$399.95



**Western Maryland** - 4-8-2 L-3 Mohawk Steam Engine  
30-1494-1 w/Proto-Sound 2.0 \$399.95

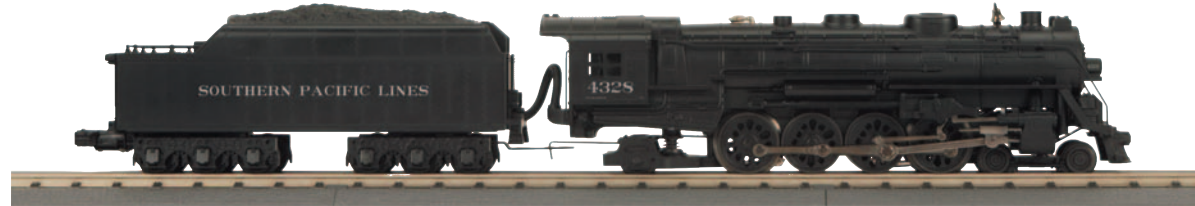

**Southern Pacific** - 4-8-2 L-3 Mohawk Steam Engine  
30-1495-1 w/Proto-Sound 2.0 \$399.95



**Jersey Central** - 4-8-2 L-3 Mohawk Steam Engine  
30-1492-1 w/Proto-Sound 2.0 \$399.95



**New York Central** - 4-8-2 Mohawk Speciality Passenger Set  
30-1496-1 w/Proto-Sound 2.0 \$499.95



**New York Central** - 4-8-2 Mohawk Speciality Freight Set  
30-1497-1 w/Proto-Sound 2.0 \$499.95

# 4-8-8-4 BIG BOY STEAM ENGINE



**IMPERIAL**  
SERIES

## Features

- Die-Cast Boiler and Tender Body
- Die-Cast Metal Chassis
- Metal Wheels and Axles
- Constant Voltage Headlight
- Die-Cast Truck Sides
- (2) Precision Flywheel Equipped Motors
- Metal Handrails and Decorative Bell
- Decorative Metal Whistle
- Remote Controlled Proto-Coupler™
- Synchronized Puffing ProtoSmoke™ System
- Locomotive Speed Control In Scale MPH Increments
- Authentic Paint Scheme
- Real Coal Load
- Engineer and Fireman Figures
- Proto-Sound® 2.0 With The Digital Command System Featuring Freight Yard Proto-Effects™
- Unit Measures: 29 1/8" x 2 5/8" x 4"
- Operates On O-31 Curves



Just months before Pearl Harbor, the American Locomotive Company delivered the first Big Boy to the Union Pacific Railroad. The UP's Department of Research and Mechanical Standards had designed the locomotive for a specific task: to pull a 3600-ton train unassisted over the Wasatch Mountains in Utah. While the Big Boy is often cited as the biggest steam locomotive ever built, in fact it is not. The Norfolk & Western's Y6 and A, the Duluth Missabe & Iron Range's Yellowstones, and the Chesapeake and Ohio's Alleghenys were all in the same league, and some exceeded the Big Boy's weight and power.

But in the battle for hearts and minds, the Big Boy won. Perhaps it was the name, simple and direct, scrawled on a locomotive under construction by an ALCo shop worker. Maybe it was timing, as the Big Boys hit the road just

when America needed symbols to rally around. Maybe the UP's publicity department just did a better job of telling the world what great equipment they had. Whatever the reason, the Big Boy captured the imagination of railfans and the American public over the ensuing years, perhaps more than any other steam engine. In many ways it is the symbolic locomotive of the American West, as big and powerful as the country it sped through.

This enduring symbol of American railroading returns to the RailKing line for 2008, complete with the industry-leading speed control, smoke output, and range of accurate sounds that characterize all MTH Proto-Sound 2.0 locomotives. Both engine and tender are constructed of die-cast metal and adorned with detail. Our model features two motors and four traction tires for pulling power and speed that rival the original Big Boy.

### Did You Know?

Writer Henry Comstock beautifully described the Big Boy's place at the apex of steam engine history: "A Union Pacific 'Big Boy' was 604 tons and 19,000 cubic feet of steel and coal and water, poised upon 36 wheels spaced no wider apart than those of an automobile. That it could thunder safely over undulating and curved track at speeds in excess of 70 miles an hour was due in large measure to the efforts of two long-forgotten pioneers. As early as 1836, the basic system that held its wheels in equalized contact with the rails was patented by a Philadelphian named Joseph Harrison; and a French technical writer, Anatole Mallet, first thought to couple two driving units heel to toe below one boiler in 1874."



**Union Pacific** - 4-8-8-4 Big Boy Steam Engine  
30-1512-1 w/Proto-Sound 2.0 \$699.95



**Union Pacific** - 4-8-8-4 Big Boy Speciality Freight Set  
30-1513-1 w/Proto-Sound 2.0 \$799.95



**Union Pacific** - 4-8-8-4 Big Boy Speciality Passenger Set  
30-1514-1 w/Proto-Sound 2.0 \$799.95

# 4-6-4 STREAMLINED HUDSON STEAM ENGINE



## Features

- Die-Cast Boiler and Tender Body
- Metal Wheels and Axles
- Constant Voltage Headlight
- Die-Cast Truck Sides
- Precision Flywheel Equipped Motor
- Remote Controlled Proto-Coupler™
- Metal Handrails
- Operating Tender Back-up Light
- Locomotive Speed Control In Scale MPH Increments
- Engineer and Fireman Figures
- Real Coal Load
- Colorful Paint Scheme
- Synchronized Puffing ProtoSmoke™ System
- Proto-Sound® 2.0 With The Digital Command System Featuring Passenger Station Proto-Effects™
- Unit Measures: 22 5/16" x 2 1/2" x 3 3/4"
- Operates On O-31 Curves

The 4-6-4 Hudson was a natural progression from the 4-6-2 Pacific, the standard passenger engine of the early 20th century. By the Roaring 20s, the popularity of rail travel and the conversion of passenger fleets from wood cars to steel was taxing the ability of Pacifics on many railroads. The larger, 4-wheel trailing truck on a Hudson allowed a bigger firebox that generated more steam, and thus, more power. Some roads went even further and added another pair of drivers to create a 4-8-4 Northern, but the Hudson was big enough for roads in primarily flat territory — most notably the New York Central with its famous Water Level Route from New York to the Midwest. As the most prominent user of 4-6-4s, the NYC also got naming rights, and the wheel arrangement was named after the Hudson River flowed alongside its tracks.

When the nation slid into the Depression in the 1930s, passenger travel fell off dramatically. In an effort to revive their fortunes, railroads turned to a new look — streamlining — to make train travel look modern and exciting. In some cases that meant entirely new streamlined trains like the Union Pacific M-10000 shown elsewhere in this catalog. Other railroads turned their efforts toward streamlined steam. At its worst, streamlining produced steam locomotives that looked like upside-down bathtubs. But at its best it yielded results like the New York Central's Dreyfus Hudsons and the Norfolk & Western "J".

For less well-heeled railroads, however, streamlining often meant some added sheet metal on existing steamers to gussy them up. So it was with the Wabash. Short of passenger power in the mid-1940s, it rebuilt seven older 2-8-2 freight engines into semi-streamlined Class P1 Hudsons. The last engines built, nos. 705 and 706, sported tall "elephant ear" smoke deflectors on either side of the smoke box, designed to deflect smoke up and out of the engineer's line of vision. Decked out with the Wabash "Follow the Flag" logo, the P1s worked in passenger service until retirement in 1956.



**Wabash** - 4-6-4 Streamlined Hudson Steamer  
30-1511-1 w/Proto-Sound 2.0 \$399.95

**ADD A MATCHING PASSENGER SET!**

See Page 66



**Erie** - 4-6-4 Streamlined Hudson Steamer  
30-1508-1 w/Proto-Sound 2.0 \$399.95

**ADD A MATCHING PASSENGER SET!**

See Page 66



**Grand Trunk Western** - 4-6-4 Streamlined Hudson Steamer  
30-1509-1 w/Proto-Sound 2.0 \$399.95

**ADD A MATCHING PASSENGER SET!**

See Page 66



**Great Northern** - 4-6-4 Streamlined Hudson Steamer  
30-1510-1 w/Proto-Sound 2.0 \$399.95

**ADD A MATCHING PASSENGER SET!**

See Page 66



## 2-6-6-6 ALLEGHENY STEAM ENGINE

**IMPERIAL**  
SERIES

### Features

- Die-Cast Boiler and Tender Body
- Metal Wheels and Axles
- Constant Voltage Headlight
- Die-Cast Truck Sides
- (2) Precision Flywheel Equipped Motors
- Remote Controlled Proto-Coupler™
- Metal Handrails
- Operating Tender Back-up Light
- Real Coal Load
- Locomotive Speed Control In Scale MPH Increments
- Engineer and Fireman Figures
- Colorful Paint Scheme
- Synchronized Puffing ProtoSmoke™ System
- Proto-Sound® 2.0 With The Digital Command System Featuring Freight Yard Proto-Effects™
- Unit Measures: 27 3/8" x 2 5/8" x 3 5/16"
- Operates On O-31 Curves

### Did You Know?

Almost half the Alleghenies, which the War Production Board allowed to continue being built throughout World War II, were equipped with steam heat and signal lines for passenger service. These were sometimes used for troop trains.



By 1940, C&O was looking for some new muscle to push, pull, and drag coal loads over the mountains between West Virginia and the eastern seaboard. Lima Locomotive Works knew they could design something that would fill C&O's needs even better than the big-boilered Texas 2-10-4s the railroad considered buying. The resulting locomotive was the 2-6-6-6 Allegheny (named for the tough mountain range it had to conquer), first delivered in 1941. The six-wheeled trailing truck that gave this locomotive a new wheel design was necessary because the firebox was located completely behind the drivers.

Not only did engineers have to add an extra set of wheels to the trailing truck, but they had to give the tender an unusual fourth pair of wheels on the rear truck. The Class H-8 Alleghenies required huge tenders—each carrying 25,000 gallons of water and 25 tons of coal. But because they still had to fit on the C&O's 115-foot turntables, the tank was made taller in the rear. The extra weight required extra wheels to support it. Other railroads, like the Virginian Railroad, that had to traverse similar mountainous territory also bought Alleghenies.

M.T.H. is proud to return the 2-6-6-6 Allegheny to our RailKing line, this time in all-new Imperial detail.



**Chesapeake & Ohio** - 2-6-6-6 Allegheny Steam Engine  
30-1504-1 w/Proto-Sound 2.0 \$699.95



**Chesapeake & Ohio** - 2-6-6-6 Allegheny Steam Engine  
30-1505-1 w/Proto-Sound 2.0 \$699.95



**Norfolk Western** - 2-6-6-6 Allegheny Steam Engine  
30-1507-1 w/Proto-Sound 2.0 \$699.95



**Great Northern** - 2-6-6-6 Allegheny Steam Engine  
30-1506-1 w/Proto-Sound 2.0 \$699.95



# SD-9 DIESEL ENGINE

## Features

- Directionally Controlled Headlights
- Intricately Detailed ABS Body
- Metal Wheels, Axles and Gears
- Die-Cast Truck Sides, Pilots and Fuel Tank
- (2) Remotely Controlled Proto-Couplers™
- Colorful Paint Scheme
- Metal Chassis
- Metal Handrails and Decorative Horn
- (2) Precision Flywheel Equipped Motors
- Locomotive Speed Control In Scale MPH Increments
- Lighted Cab Interior
- (2) Engineer Cab Figures
- Operating Smoke Unit
- Proto-Sound® 2.0 With The Digital Command System Featuring Freight Yard Proto-Effect™
- Unit Measures: 16" x 2 3/4" x 4"
- Operates On O-31 Curves

## Did You Know?

A special version of the SD9, the SD9s, was a lightweight locomotive used primarily for branch-line service.





In the General Motors' Electro-Motive Division time line, 1954 holds significance for two important events. In that year, the manufacturer produced its 15,000th locomotive and introduced the 1,750-h.p. SD9. The road switcher was produced until 1959. Basically an elongated — and, some might say, handsomer — version of EMD's very popular GP9, the SD9 spread the same horsepower over two additional axles, resulting in a lower loading on each axle. This made the engine more suitable for use on light rail and in situations requiring power at low speeds, such as hump yard service.

The RailKing Scale model of the SD9 is built to 1/48th scale proportions and is thus somewhat larger than typical RailKing diesels. O gauge operators looking for scale proportioned locomotives will find durable, yet well detailed, RailKing Scale models to be an excellent alternative to more expensive O scale diesels.



**Burlington** - SD-9 Diesel Engine

30-2872-1	w/Proto-Sound 2.0	\$299.95
30-2872-3	Non-Powered	\$149.95



**Pennsylvania** - SD-9 Diesel Engine

30-2873-1	w/Proto-Sound 2.0	\$299.95
30-2873-3	Non-Powered	\$149.95



**Baltimore & Ohio** - SD-9 Diesel Engine

30-2870-1	w/Proto-Sound 2.0	\$299.95
30-2870-3	Non-Powered	\$149.95



**Southern Pacific** - SD-9 Diesel Engine

30-2875-1	w/Proto-Sound 2.0	\$299.95
30-2875-3	Non-Powered	\$149.95



**Bessemer & Lake Erie** - SD-9 Diesel Engine

30-2871-1	w/Proto-Sound 2.0	\$299.95
30-2871-3	Non-Powered	\$149.95



**Southern** - SD-9 Diesel Engine

30-2874-1	w/Proto-Sound 2.0	\$299.95
30-2874-3	Non-Powered	\$149.95

# EMD F3 A-B-A DIESEL SET



**RAILKING**  
scale



## Features

- Colorful Paint Scheme
- Die-Cast Metal Chassis
- Die-Cast Truck Sides, Pilots and Fuel Tank
- Metal Wheels, Axles and Gears
- (2) Precision Flywheel Equipped Motors In Powered A Unit
- (2) Remotely Controlled Proto-Couplers™ (one per A Unit)
- Directionally Controlled Headlights
- Intricately Detailed ABS Bodies
- Locomotive Speed Control In Scale MPH Increments
- Engineer Cab Figure In Each A Unit
- Proto-Sound® 2.0 With The Digital Command System Featuring Freight Yard or Passenger Station Proto-Effects™
- Operating Smoke Unit In Powered A Unit
- Unit Measures: 40 1/4" x 2 5/8" x 3 3/4"
- Operates On O-31 Curves

When the prototype railroads began to dieselize in the 1940s, model train manufacturers soon followed, recognizing that boys wanted models of the newest trains they were seeing on real railroads. One of the initial toy train forays into dieseldom was a replica of the best-selling diesel of the day, the F3 "covered wagon" made by the Electro Motive Division of General Motors.

Recognizing that EMD and the railroads were anxious to publicize their modern motive power, General Motors, the Santa Fe Railroad, and the New York Central Railroad helped share the cost of dies for the original models in exchange for having their names on engines that appeared on virtually every boy's holiday wish list for years. In the end, it seems the Santa Fe got the best deal, as its red, yellow, and silver "warbonnet" F3s remained a popular fixture on model railroad locomotives longer than any other railroad livery.

To this day, the F3 diesels of the late 1940s and early 1950s are recognized as some of the best toys ever produced. Virtually full O gauge scale models, they were tremendously dependable, highly detailed for their time, and terrific pullers.

Postwar and RailKing Scale fans will no doubt want to order this stellar M.T.H. replica of model railroading's most famous diesel. The look and feel of the classic original is faithfully reproduced, right down to the die-cast metal chassis. Under the hood, however, lies the power and performance of Proto-Sound 2.0, twin flywheel-equipped motors, and Proto-Smoke, offering today's model railroaders an operating experience that boys of the 1950s could only dream about.

### Did You Know?

In a December 1950 radio show, famed comedian Jack Benny wrote a letter to Dear Santa Fe, saying "Christmas is almost here and it would make me happy if you gave me a train." While the railroad did not give Benny the real train he asked for, its publicity department did send him a toy train model of the F3.



**Caterpillar®** - F-3 A-B-A Diesel Engine Set  
30-2849-1 w/Proto-Sound 2.0 \$499.95



© 2008 Caterpillar  
CAT, CATERPILLAR, their respective logos, "Caterpillar Yellow" and the POWER EDGE trade dress, as well as corporate and product identity used herein, are trademarks of Caterpillar and may not be used without permission.



**Pennsylvania** - F-3 A-B-A Diesel Engine Set  
30-2850-1 w/Proto-Sound 2.0 \$499.95



**Great Northern** - F-3 A-B-A Diesel Engine Set  
30-2852-1 w/Proto-Sound 2.0 \$499.95

**ADD A MATCHING PASSENGER SET!**

See Page 69



**Chesapeake & Ohio** - F-3 A-B-A Diesel Engine Set  
30-2851-1 w/Proto-Sound 2.0 \$499.95

**ADD A MATCHING PASSENGER SET!**

See Page 69



**Harley-Davidson®** - F-3 A-B-A Diesel Engine Set  
30-2853-1 w/Proto-Sound 2.0 \$499.95



© 2008 H-D, All Rights Reserved.

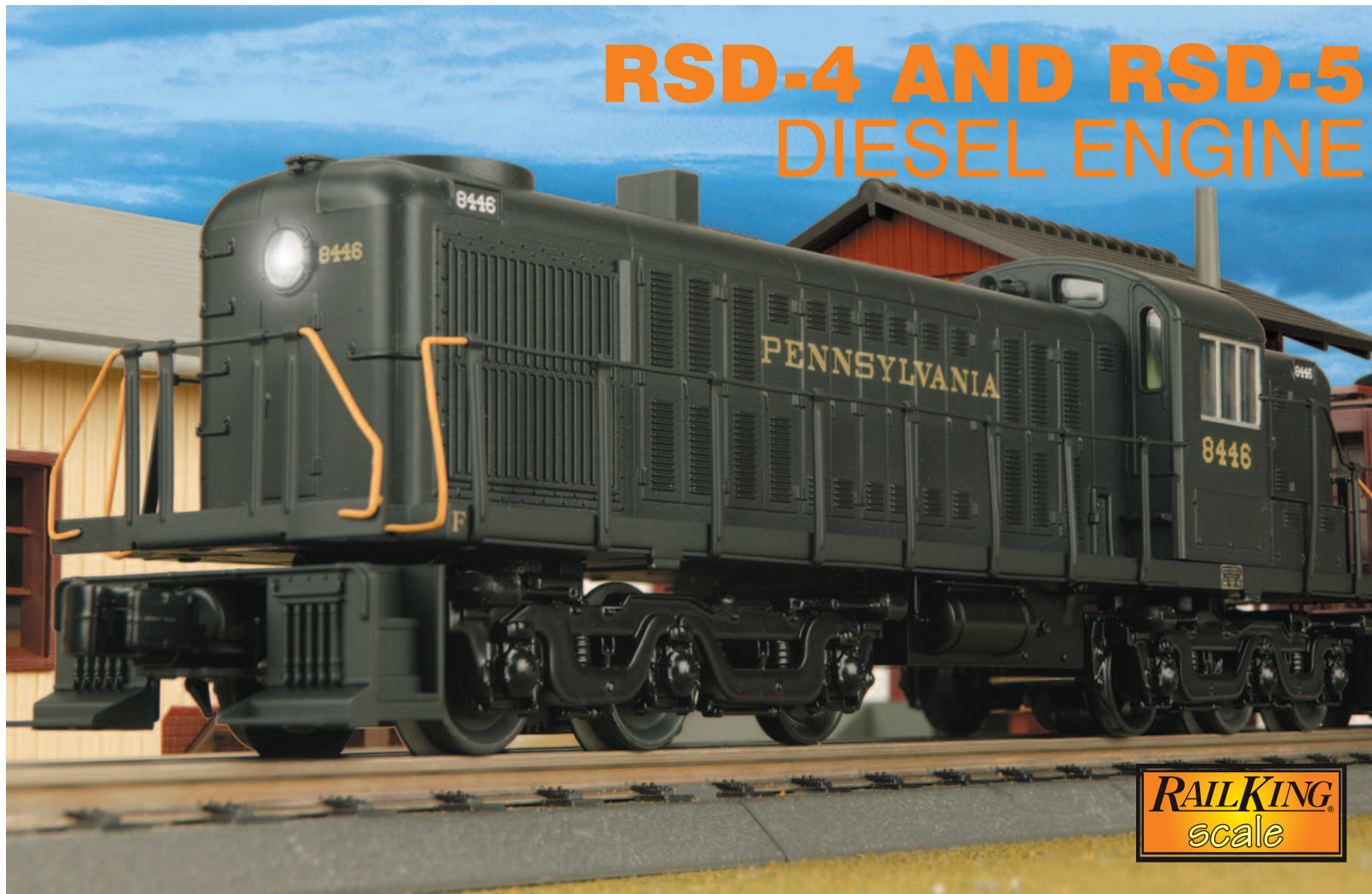

## Features

- Die-Cast Truck Sides, Pilots and Fuel Tank
- Colorful Paint Scheme
- Metal Chassis
- Metal Handrails and Decorative Horn
- Intricately Detailed ABS Body
- Locomotive Speed Control In Scale MPH Increments
- (2) Precision Flywheel Equipped Motors
- (2) Remotely Controlled Proto-Couplers™
- Metal Wheels, Axles and Gears
- Directionally Controlled Headlights
- Proto-Sound® 2.0 With The Digital Command System Featuring Freight Yard Proto-Effects™
- Unit Measures: 14 1/2" x 2 1/2" x 3 3/4"
- Operates On O-31 Curves

## Did You Know?

While they were the first to be cataloged, the RSC-2s were not the first six-axle Alco RS locomotives. Back in World War II, the first two years of RS-1 production had gone to the military. The 13 units that had been delivered to American railroads were requisitioned from their owners and, along with 144 additional engines, were sent to Iran, Russia, and U.S. Army posts. These RS-1s were fitted with three-axle trucks to make them suitable for lighter rail on overseas roads. A group that plied the Trans-Iranian Railroad became known as "the diesels that saved Russia" because they brought in food and other supplies after the Luftwaffe had crippled Russian shipping. These engines later became the prototype for Russia's own early diesels.

The American Locomotive Company pioneered the multi-purpose "road switcher" design in 1941 with its 1000 hp RS-1. Alco's designers added a second, shorter hood to a basic switcher to make room for a steam boiler for passenger train heat. The short hood also afforded the crew additional accident protection. Smoother-riding trucks made Alco's new design suitable for the higher road speeds that would be daunting in a typical switcher.

In 1946, Alco cataloged the first six-axle version of its road switcher, the RSC-2. Designed for operation on the lighter rail found on branch lines and short lines, the engine used two more axles to spread out its weight. The trucks were a so-called "A1A" configuration: the two end axles had traction motors while the middle wheels were unpowered idlers.

In 1951, the Chicago and Northwestern asked Alco to build a six-axle version of its RS-3, this time with all axles powered. The body and the 1600 hp Alco 244 prime mover were the same as used in the RS-3, but the additional traction motors gave the new model RSD-4 stronger low-speed performance. The longer trucks were both smooth-riding and more suitable for lighter rail. The design proved to be a winner, and a dozen railroads purchased the RSD-4 and its near-identical twin, the RSD-5, which sported an improved GE generator.

To receive the latest updates on catalog items, sign up for our weekly e-newsletter. Go to the News link at the top of our home page,

[www.mthtrains.com](http://www.mthtrains.com).

**Milwaukee Road** - RSD-5 Diesel Engine

30-2868-1	w/Proto-Sound 2.0	\$299.95
30-2868-3	Non-Powered	\$149.95



**Pennsylvania** - RSD-4 Diesel Engine

30-2866-1	w/Proto-Sound 2.0	\$299.95
30-2866-3	Non-Powered	\$149.95



**Southern Pacific** - RSD-4 Diesel Engine

30-2867-1	w/Proto-Sound 2.0	\$299.95
30-2867-3	Non-Powered	\$149.95



**Western Maryland** - RSD-5 Diesel Engine

30-2869-1	w/Proto-Sound 2.0	\$299.95
30-2869-3	Non-Powered	\$149.95



# ALCO PA DIESEL ENGINE

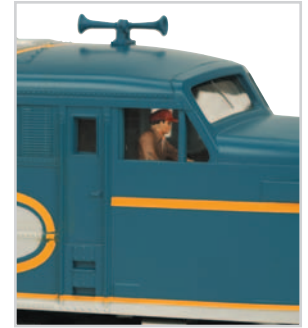

## Features

- Metal Chassis
- Intricately Detailed ABS Bodies
- Metal Wheels, Axles and Gears
- Directionally Controlled Headlights
- Die-Cast Truck Sides, Pilots and Fuel Tank
- (2) Remotely Controlled Proto-Couplers™
- Locomotive Speed Control In Scale MPH Increments
- (2) Precision Flywheel Equipped Motors
- Proto-Sound® 2.0 With The Digital Command System Featuring Passenger Station Proto-Effects™
- Unit Measures: 28 1/2" x 2 1/2" x 3 5/8"
- B-Unit Measures: 12 7/8" x 2 1/2" x 3 3/8"
- Operates On O-31 Curves

## Did You Know?

In the classification PA-1, the P stands for passenger, the A for the cab unit, and the 1 for the first model made. Later units were models PA-2 and PA-3.

The PA was Alco's glamour girl. While Electro-Motive's E-units easily beat Alco's passenger engine in terms of popularity, the PA is widely regarded as the most beautiful first-generation diesel — period. Perhaps no other locomotive looked so right at the head of the streamlined trains of the late forties and fifties that were the last hurrah of American long-distance passenger service. The 294 PA's and cableless PB's built between 1946 and 1953 powered some of the most famous name trains from coast to coast, from the Santa Fe's Super Chief to the New Haven's Merchants' Limited.

The muscular PA profile and its elegant nose with the characteristic grille around the headlight were designed by Ray Patten of General Electric. At the time, GE and Alco were partners in the locomotive business, with GE making the electrical equipment for all Alco diesels. While Alco would later fall by the wayside, GE went on to become America's largest locomotive builder by the early 1990's.

Under the hood of the PA beat a 16-cylinder model 244 prime mover that developed 2000 hp. Depending on their gearing, PA's could hustle a passenger consist along at up to 100 mph.

Long after all other PA's had gone to scrap, four restored ex-Santa Fe units remained in service on the Delaware & Hudson into the late 1970's. Sold to the Ferrocarriles Nacionales de Mexico (FNM) in 1978, most of the units eventually deteriorated to junk status, although one remained operational. But in April of 2000, Doyle McCormack — who also happens to be the engineer of 4449, the restored Southern Pacific Daylight — and the Smithsonian Institution repatriated two of the junked units for rebuilding. One of the units will be restored to Santa Fe livery for static display, while Doyle is bringing the other PA back to life in the Nickel Plate Road "Bluebird" scheme. You can follow the progress of Doyle's labor on the Web site [www.nkp190.com](http://www.nkp190.com).

Recreate the excitement of first-class passenger travel with the RailKing Alco PA locomotive and matching RailKing passenger sets. Our Proto-Sound 2.0 sound and control system brings you the authentic sounds of an Alco prime mover and the ability to start your train so gently you won't spill the water in the diner — and then accelerate up to scale speeds of over 100 mph, just like the prototype.



**New Haven** - Alco PA Diesel Set  
30-2856-1 w/Proto-Sound 2.0 \$349.95  
30-2856-3 Alco PA B Unit \$119.95

**ADD A MATCHING PASSENGER SET!**

See Page 68

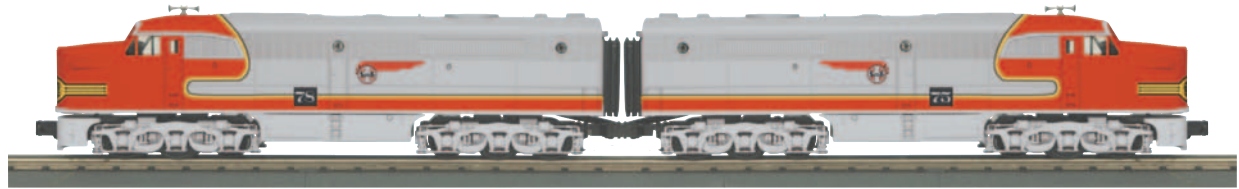

**Santa Fe** - Alco PA Diesel Set  
30-2857-1 w/Proto-Sound 2.0 \$349.95  
30-2857-3 Alco PA B Unit \$119.95

**ADD A MATCHING PASSENGER SET!**

See Page 68



**Delaware & Hudson** - Alco PA Diesel Set  
30-2854-1 w/Proto-Sound 2.0 \$349.95  
30-2854-3 Alco PA B Unit \$119.95

**ADD A MATCHING PASSENGER SET!**

See Page 68

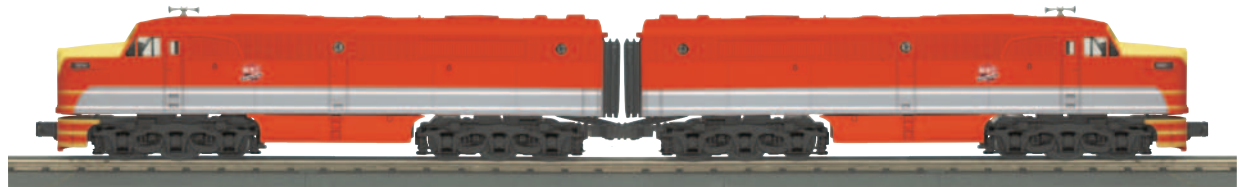

**MKT** - Alco PA Diesel Set  
30-2855-1 w/Proto-Sound 2.0 \$349.95  
30-2855-3 Alco PA B Unit \$119.95

**ADD A MATCHING PASSENGER SET!**

See Page 68

# C628 DIESEL ENGINE



## Features

- Intricately Detailed ABS Body
- Colorful Paint Scheme
- Metal Chassis
- Die-Cast Truck Sides, Pilots and Fuel Tank
- Metal Wheels, Axles and Gears
- Metal Handrails and Decorative Horn
- (2) Precision Flywheel Equipped Motors
- (2) Remotely Controlled Proto-Couplers™
- (2) Engineer Cab Figures
- Directionally Controlled Headlights
- Locomotive Speed Control In Scale MPH Increments
- Lighted Cab Interior
- Operating Smoke Unit
- Proto-Sound® 2.0 With The Digital Command System Featuring: Freight Yard Proto-Effects™
- Unit Measures: 18" x 2 1/2" x 3 3/4"
- Operates On O-31 Curves



As the competition between Alco and EMD escalated in the early 1960s, the development of Alco's Century series raised the stakes in the horsepower race.

The introduction of the Alco Century C628 featured, for the first time, a single-engine locomotive capable of producing desirable adhesion and tractive effort in a six-axle design. In fact, the C628 changed the concept of the six motor unit from that of a low-speed heavy hauler to a fast freight locomotive.

The lengthened chassis and short nose resulted from the removal of components formally found in the nose section. The carbody itself was sealed and an area directly behind the cab was reserved for a steam generator. However, since all the C628 engines were produced for freight service, the generator was not needed the space went unused.

M.T.H. brings the Century series back to life again in 2008 in the RailKing Scale category in a variety of roadnames that are sure to please.



**Santa Fe** - C628 Diesel Engine  
30-2861-1 w/Proto-Sound 2.0  
30-2861-3 Non-Powered

\$299.95  
\$149.95



**Lehigh Valley** - C628 Diesel Engine

30-2859-1 w/Proto-Sound 2.0  
30-2859-3 Non-Powered

\$299.95  
\$149.95



**Norfolk & Western** - C628 Diesel Engine

30-2860-1 w/Proto-Sound 2.0  
30-2860-3 Non-Powered

\$299.95  
\$149.95



**Delaware & Hudson** - C628 Diesel Engine

30-2858-1 w/Proto-Sound 2.0  
30-2858-3 Non-Powered

\$299.95  
\$149.95

# SW-9 SWITCHER DIESEL ENGINE

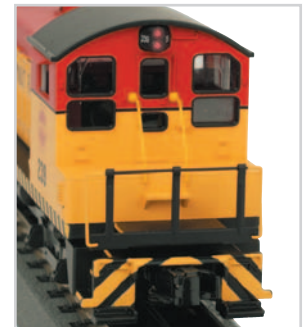

## Features

- Intricately Detailed ABS Body
- (2) Remotely Controlled Proto-Couplers™
- Die-Cast Truck Sides, Pilots and Fuel Tank
- Colorful Paint Scheme
- Die-Cast Metal Chassis
- Metal Handrails and Decorative Horn
- (2) Precision Flywheel Equipped Motors
- Directionally Controlled Headlights
- Metal Wheels, Axles and Gears
- Locomotive Speed Control In Scale MPH Increments
- Proto-Sound® 2.0 With The Digital Command System Featuring Freight Yard Proto-Effects™
- Unit Measures: 12" x 2 1/2" x 3 1/2"
- Operates On O-31 Curves



**Frisco** - SW-9 Switcher Diesel Engine

30-2884-1	w/Proto-Sound 2.0	\$299.95
30-2884-3	Non-Powered Calf	\$119.95

EMD's 800-hp SW-8s and 1,200-hp SW-9s both debuted in 1950, marking the next stage in the evolution of one of railroading's longest-lived diesel families. The first SW-class engine, the 600-hp SW1, appeared in 1939, and the SW-units remained in the EMD catalog until the 1,000-hp SW-1000 was finally retired in 1986. With the "SW" in the name denoting that the engine was built for switching duties, it never needed the high horsepower ratings of road diesels. They could be paired with cab-less "calf" units in the classic cow and calf configuration if a particular job needed more power.

These boxy little workhorses return to the M.T.H. RailKing lineup in 2008 in a new variety of road-names. As with all RailKing diesel engines, each is available with the exciting Proto-Sound 2.0 system for unprecedented value and fun. As switch locomotives, the SWs are perfect for yard duty thanks to their incredible slow-speed performance - performance governed by M.T.H.'s industry-leading Proto-Speed speed control system. No other switchers can creep so slow or uncouple cars from front or rear without additional equipment. If you've got a transformer with a whistle and bell button, you've got the best switcher you can buy today.

### Did You Know?

While the SW-8s and -9s were produced as replacements for the aging NW-2 diesel switcher, they proved themselves impervious to age themselves, becoming railyard mainstays for decades

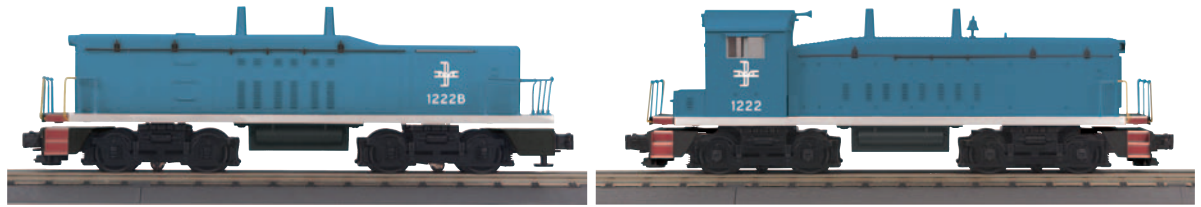

**Boston & Maine** - SW-9 Switcher Diesel Engine  
 30-2882-1 w/Proto-Sound 2.0 \$299.95  
 30-2882-3 Non-Powered Calf \$119.95

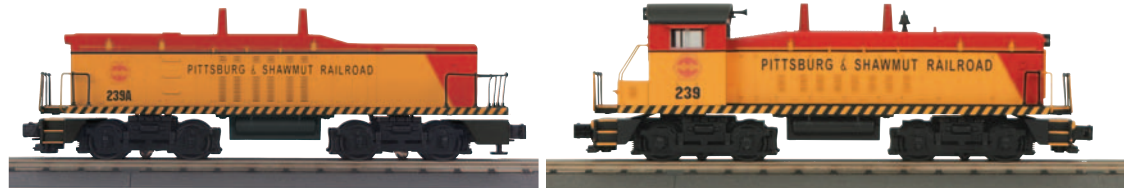

**Pittsburgh & Shawmut** - SW-9 Switcher Diesel Engine  
 30-2886-1 w/Proto-Sound 2.0 \$299.95  
 30-2886-3 Non-Powered Calf \$119.95



**Chessie** - SW-9 Switcher Diesel Engine  
 30-2883-1 w/Proto-Sound 2.0 \$299.95  
 30-2883-3 Non-Powered Calf \$119.95



**New York Central** - SW-9 Switcher Diesel Engine  
 30-2885-1 w/Proto-Sound 2.0 \$299.95  
 30-2885-3 Non-Powered Calf \$119.95



**Southern Pacific** - SW-9 Switcher Diesel Engine  
 30-2887-1 w/Proto-Sound 2.0 \$299.95  
 30-2887-3 Non-Powered Calf \$119.95

# EMD SD70ACe DIESEL ENGINE

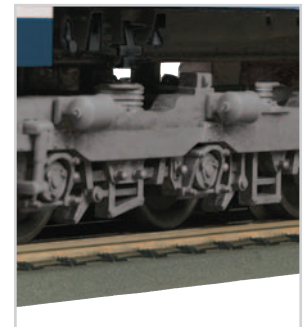
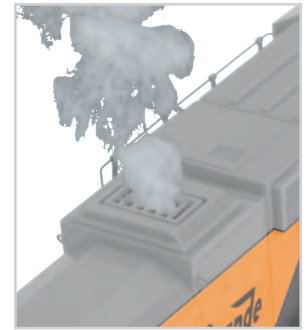

## Features

- Constant Voltage Headlight
- Intricately Detailed ABS Body
- Metal Wheels, Axles and Gears
- Die-Cast Truck Sides, Pilots and Fuel Tank
- (2) Remotely Controlled Proto-Couplers™\*
- Colorful Paint Scheme
- Metal Chassis
- Metal Handrails and Decorative Horn
- (2) Precision Flywheel Equipped Motors
- Locomotive Speed Control In Scale MPH Increments
- Operating Horn and Bell
- Operating Smoke Unit
- Operating Ditch Lights
- Proto-Sound® 2.0 With The Digital Command System Featuring Freight Yard Proto-Effects™\*
- Unit Measures:
- Operates On O-31 Curves

## HERITAGE SERIES!

**ADD MATCHING HIGH-CUBE  
BOX CARS & BAY WINDOW  
CABOOSE**

See Page 64-67

\* Available on Proto-Sound 2.0 Models Only

The SD70ACe is Electro-Motive Division's hope for the future. While designed to meet the Environmental Protection Agency's Tier-2 emissions requirements that took effect on January 1, 2005, this replacement for the SD70MAC also seems to have a higher purpose: to recapture the lead in North American locomotive sales that EMD lost to General Electric in 1987.

Under the hood beats a third-generation model 710 diesel with 4300 horsepower; only slight modifications were needed to make the model 710 meet new emission standards. With 5000 such motors in service worldwide and a reputation for dependability, EMD reasoned that shop crews would prefer familiar technology.

Other than the prime mover, however, virtually every element of the SD70ACe has been rethought to create a 21st century locomotive. Ergonomics were a prime consideration. The engine's angular nose offers the crew far better visibility than most other locomotives, and the cab is comfortable for engineers of almost any size. Digital screens provide a range of information on what is happening both inside the locomotive and out on the road. The cab easily accommodates a crew of three — an important factor in a modern world without cabooses. And there is, of course, a cupholder for the engineer.

New for 2008, M.T.H. offers the SD70ACe as our first RailKing Imperial diesel, accurately decorated in the six paint schemes that comprise the Union Pacific heritage fleet. Each one-of-a-kind locomotive honors a "fallen flag" railroad that is now part of the Union Pacific system. Our near-scale model is a full 17" in length, yet operates comfortably on O-31 curves. Imperial features include operating diesel exhaust smoke and flashing ditch lights. Under the hood is the same Proto-Sound 2.0 system found in our more expensive Premier version of this locomotive, complete with sounds recorded from an actual Union Pacific SD70ACe. If you're looking for realism and a lot of fun at a RailKing price, it doesn't get any better than this!

**NEW!****Missouri Pacific** - SD70ACe Diesel Engine

30-2878-1	w/Proto-Sound 2.0	\$299.95
30-2878-0	w/Horn & Bell	\$229.95

**NEW!****Western Pacific** - SD70ACe Diesel Engine

30-2881-1	w/Proto-Sound 2.0	\$299.95
30-2881-0	w/Horn & Bell	\$229.95

**NEW!****Southern Pacific** - SD70ACe Diesel Engine

30-2880-1	w/Proto-Sound 2.0	\$299.95
30-2880-0	w/Horn & Bell	\$229.95

**NEW!****MKT** - SD70ACe Diesel Engine

30-2879-1	w/Proto-Sound 2.0	\$299.95
30-2879-0	w/Horn & Bell	\$229.95

**NEW!****Denver Rio Grande** - SD70ACe Diesel Engine

30-2877-1	w/Proto-Sound 2.0	\$299.95
30-2877-0	w/Horn & Bell	\$229.95

**NEW!****Chicago Northwestern** - SD70ACe Diesel Engine

30-2876-1	w/Proto-Sound 2.0	\$299.95
30-2876-0	w/Horn & Bell	\$229.95

# EMD F59PHI DIESEL ENGINE



**IMPERIAL**  
SERIES

## Features

- Directionally Controlled Headlight
- Intricately Detailed ABS Body
- Colorful Paint Scheme
- (2) Precision Flywheel Equipped Motors
- Operating Smoke Unit
- Die-Cast Truck Sides, Pilots and Fuel Tank
- Metal Wheels, Axles and Gears
- (2) Remotely Controlled Proto-Couplers™
- Metal Chassis
- Locomotive Speed Control In Scale MPH Increments
- Operating Ditch Lights
- Proto-Sound® 2.0 With The Digital Command System Featuring Passenger Station Proto-Effects™
- Unit Measures: 14 1/8" x 2 7/16" x 3 3/4"
- Operates On O-27 Curves

## Did You Know?

The addition of a separate motor/generator for head end power in the F59 eliminated an annoyance with the older F40PH, which had only a single motor: the prime mover in the F40 had to run at full throttle all the time, even when a train was stopped, in order to provide light and climate control to the passenger coaches. In fact a small number of F40's were built with a longer carbody to accommodate a separate HEP diesel motor.

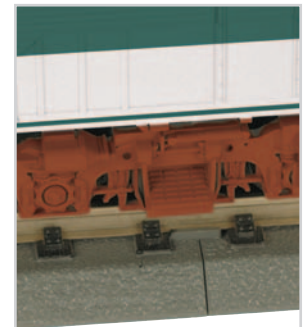

In 1988 Toronto-area commuter operator GO transit commissioned EMD to design a new commuter locomotive to replace the aging F40PH — which had been North America's standard passenger engine for more than a decade. The new F59PH design incorporated a 3000 horsepower prime mover and a separate head end power (HEP) motor/generator set for car lighting, heat, and air conditioning. The new engine used 12 cylinders instead of 16 to produce the same horsepower as the seventies-era F40PH, and with lower emissions. On the exterior, however, the F59 didn't look like a new passenger engine; it had the boxy, muscular look of a freight hauler.

The Canadian-born design really came into its own on the West Coast of the United States. In 1994 the California Department of Transportation placed an order for nine F59's for "Amtrak California" service and specified a new look that, while officially designated the F59PHI, became known as the California F59: rounded nose, side skirts covering the fuel tank, and a streamlined carbody to blend with high, bilevel passenger cars. Other railroads apparently liked the new look and the engine's performance, and the F59PHI became a common sight on the West Coast. Commuter operators include Metrolink in Los Angeles, Translink in Vancouver, B.C., and Seattle's Sound Transit "Sounder" service. On the other side of the continent, F59PHI's can be found on Montreal commuter runs and Amtrak service out of Raleigh, North Carolina.

Replicate the services that are reviving commuter rail travel in many parts of the United States with MTH's RailKing Imperial Series F59PHI and matching passenger consists. The F59PHI sports operating smoke and operating ditch lights guaranteed to attract attention on your layout.

## ADD A MATCHING PASSENGER SET!

See Page 69



**Amtrak** - F59PHI Diesel Engine  
30-2862-1 w/Proto-Sound 2.0 \$299.95

## ADD A MATCHING PASSENGER SET!

See Page 69



**Amtrak** - F59PHI Diesel Engine  
30-2863-1 w/Proto-Sound 2.0 \$299.95

## ADD A MATCHING PASSENGER SET!

See Page 69

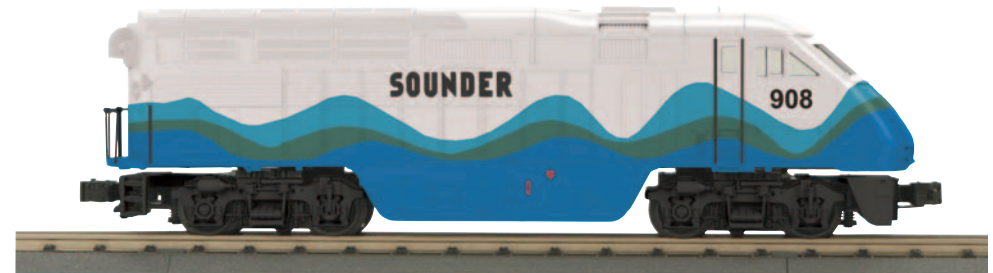

**Sounder** - F59PHI Diesel Engine  
30-2865-1 w/Proto-Sound 2.0 \$299.95

## ADD A MATCHING PASSENGER SET!

See Page 69



**Metrolink** - F59PHI Diesel Engine  
30-2864-1 w/Proto-Sound 2.0 \$299.95



# BUMP-N-GO TROLLEY

## Features

- Intricately Detailed ABS Body
- Metal Wheels, Axles and Gears
- Colorful Paint Scheme
- Precision Motor
- Lighted Interior
- Moveable Power Pole
- Automatic Reversing Bumpers
- Unit Measures: 8 1/4" x 2 3/8" x 3 1/3"
- Operates On O-27 Curves

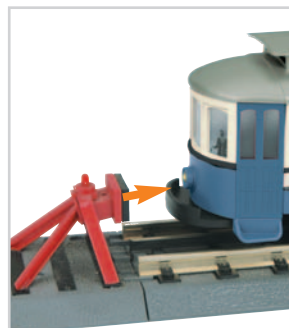



Introduce someone you love to model railroading with the magic of a Bump-n-Go Trolley.

The colorful trolley features a lighted interior, metal wheels and gears and a long-lasting motor. The unit operates on any O Gauge track system and features an Automatic Bumper Reversing Mechanism (ABRM) that changes the car's direction when it hits a track bumper.



**Main Street** - Bump-n-Go Trolley  
30-2562 \$59.95



**Pittsburgh** - Bump-n-Go Trolley  
30-2585 \$59.95

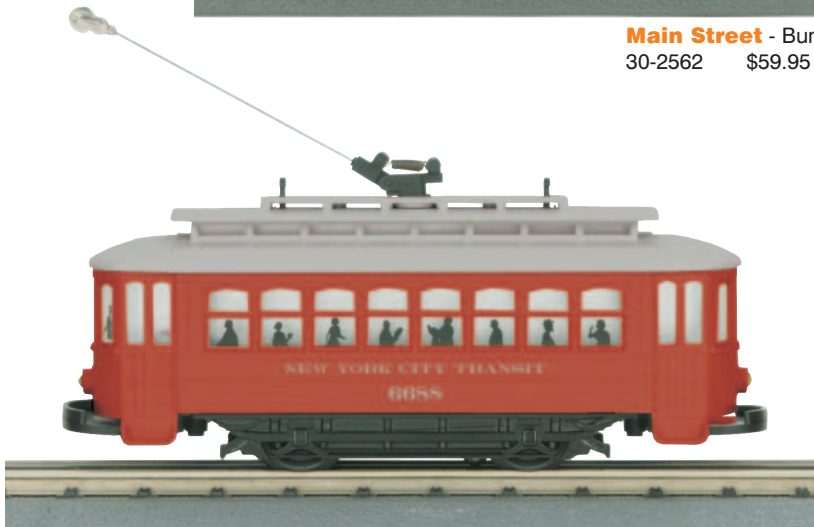

**New York Transit** - Bump-n-Go Trolley  
30-2596 \$59.95

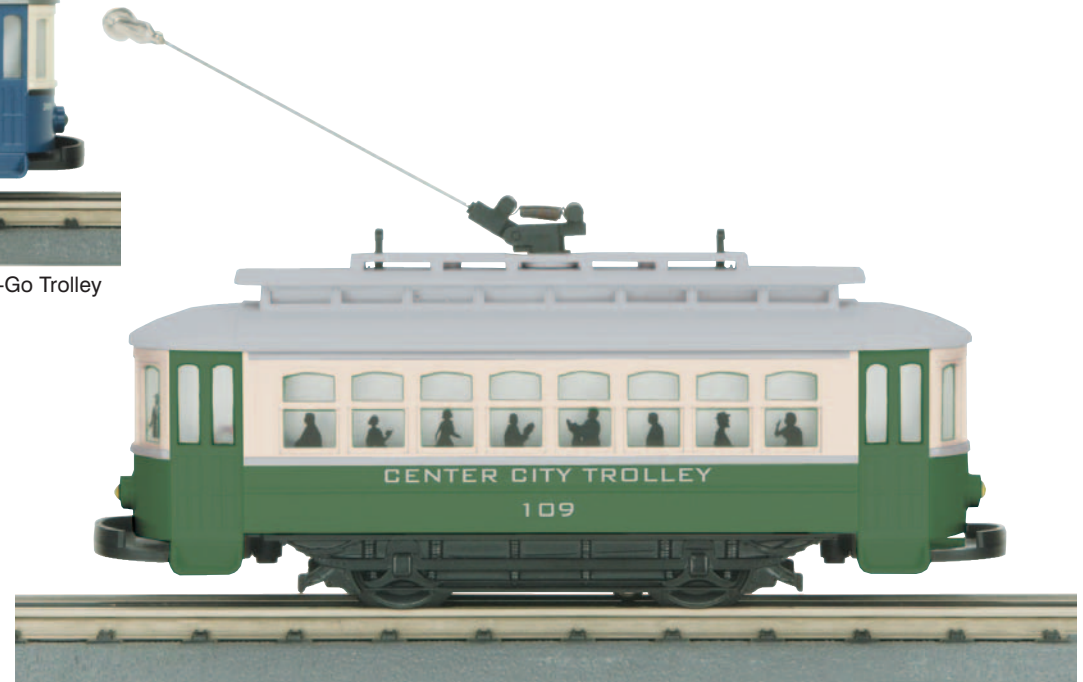

**Center City** - Bump-n-Go Trolley  
30-2545 \$59.95

# RailKing Freight

High quality, traditionally sized RailKing Freight Cars provide detailed bodies and colorful paint schemes for the O Gauge railroader. MTH makes an enormous variety of RailKing Freight Cars, including many different car types and roadnames. No matter what era or part of the country you are modeling, RailKing is sure to have something for you.

## Freight Features

- Intricately Detailed Durable ABS Body
- Metal Wheels and Axles
- Die-Cast 4-Wheel Trucks
- Operating Die-Cast Metal Couplers
- Colorful, Attractive Paint Schemes
- Decorative Brake Wheels
- Opening Car Doors on Most Cars
- Separate Metal Handrails
- Fast-Angle Wheel Sets
- Needle-Point Axles

# Operating Action Car

This exciting car features a backlighting moving animation strip visible through each of the car's four large viewing windows. Utilizing a quiet and efficient motorized player and bright LED lighting, the animated action really shines bright!



**Coors Light** - Operating Action Car  
30-79225 \$69.95

© 2008 Molson Coors Global Properties, LLC Coors trademarks are properties of Molson Coors Global Properties, LLC, used under license by M.T.H. Electric Trains Limited Edition Adult Collectible-This licensed product is intended for purchase and enjoyment by individuals of legal purchase age for alcohol beverages.



**M&M'S®** - Operating Action Car  
30-79226 \$69.95



®/™ M&M'S, the letter M and the M&M'S Characters are registered trademarks of Mars, Incorporated and its affiliates.  
©MARS, Incorporated 2008

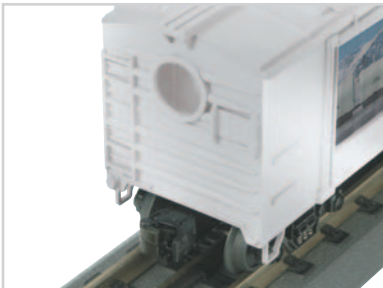

## Details

- Moving Backlit Scenes
- Unit Measures: 11 1/2" x 2 3/8" x 2 5/16"
- Operates On O-27 Curves

# Reefer Car



**Bikini Ale** - Reefer Car  
30-78082 \$39.95



**Duke's Beer** - Reefer Car  
30-78083 \$39.95

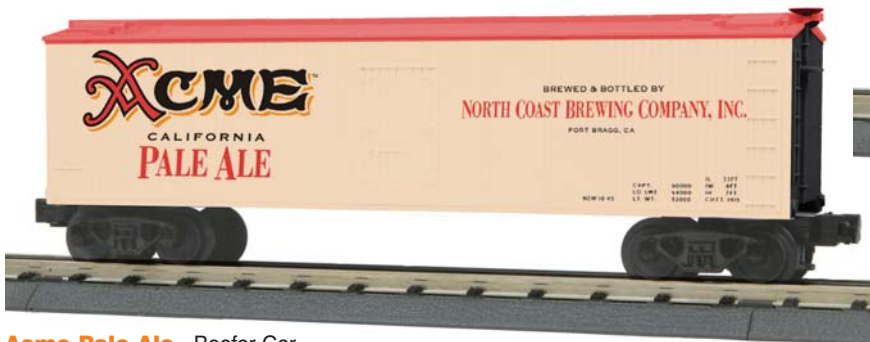

**Acme Pale Ale** - Reefer Car  
30-78081 \$39.95



**Leatherneck Lager** - Reefer Car  
30-78084 \$39.95

## Details

- Unit Measures: 11 5/8" x 2 1/2" x 3 3/16"
- Operates On O-27 Curves



# Modern Reefer



**A&W Root Beer** - Modern Reefer  
30-78076 \$47.95

A&W is a trademark of A&W Concentrate Company, used under license by M.T.H. Electric Trains. ©2008 A&W Concentrate Company



**7UP** - Modern Reefer  
30-78074 \$47.95

7UP is a trademark of Dr Pepper/Seven Up, Inc., used by M.T.H. Electric Trains under license. ©2008 Dr Pepper/Seven up, Inc.

## Details

- Unit Measures: 11 1/2" x 2 3/8" x 2 5/16"
- Operates On O-27 Curves

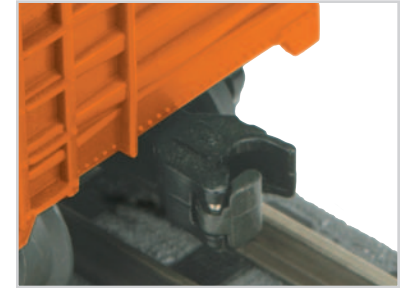

**Dr Pepper** - Modern Reefer  
30-78073 \$47.95

DR PEPPER is a trademark of Dr Pepper/Seven Up, Inc., used by M.T.H. Electric Trains under license. ©2008 Dr Pepper/Seven up, Inc.



**Hires Rootbeer** - Modern Reefer  
30-78075 \$47.95

HIRES is a trademark of Dr Pepper/Seven Up, Inc., used by M.T.H. Electric Trains under license. ©2008 Dr Pepper/Seven up, Inc.



**Winterbraun Holiday Ale** - Modern Reefer  
30-78077 \$44.95



**Old Detroit Red Lager** - Modern Reefer  
30-78080 \$44.95



**El Nino Dubbel Ale** - Modern Reefer  
30-78078 \$44.95



**Buffalo Butt Beer** - Modern Reefer  
30-78079 \$44.95



# 4-Bay Hopper



**Pittsburg & Shawmut** - 4-Bay Hopper  
30-75285 \$39.95



**Union Pacific** - 4-Bay Hopper  
30-75287 \$39.95

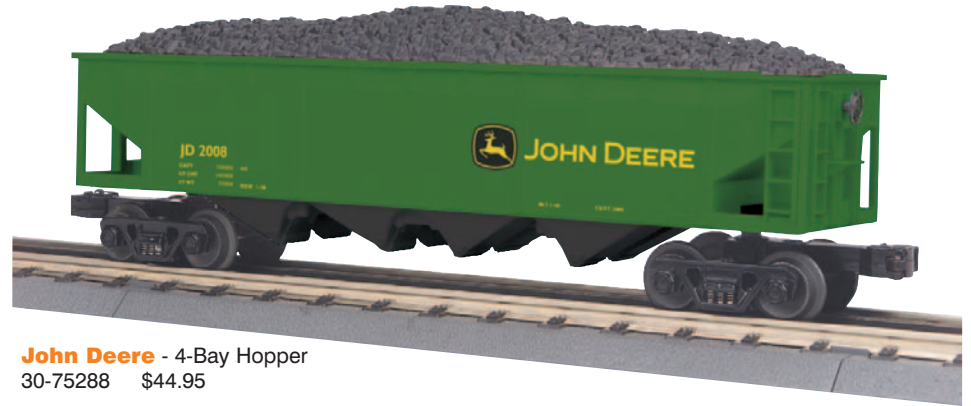

**John Deere** - 4-Bay Hopper  
30-75288 \$44.95

John Deere is a registered trademark of Deere & Company.



**CSX** - 4-Bay Hopper  
30-75286 \$39.95

## Details

- Unit Measures: 11 3/4" x 2 1/2" x 2 3/4"
- Operates On O-27 Curves

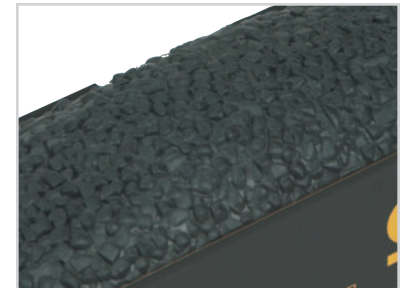

# 4-Bay Cylindrical Hopper



**Canada** - 4-Bay Cylindrical Hopper  
30-75290 \$42.95



**Alberta** - 4-Bay Cylindrical Hopper  
30-75289 \$42.95



**Canadian National** - 4-Bay Cylindrical Hopper  
30-75291 \$42.95



**Saskatchewan** - 4-Bay Cylindrical Hopper  
30-75292 \$42.95



## Details

- Unit Measures: 13 3/8" x 2 3/8" x 3 7/16"
- Operates On O-31 Curves

# Modern Tank Car



**CP Rail** - Modern Tank Car  
30-73277 \$44.95



**New Haven** - Modern Tank Car  
30-73278 \$44.95

## Details

- Unit Measures: 10 7/8" x 2 3/8" x 3 7/8"
- Operates On O-27 Curves



**Alaska** - Modern Tank Car  
30-73276 \$44.95



**Western Maryland** - Modern Tank Car  
30-73279 \$44.95

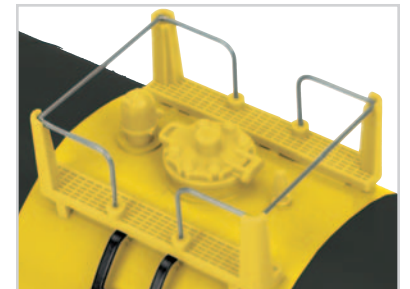



# 3-Dome Tank Car



**Monon** - 3-Dome Tank Car  
30-73273 \$44.95



**Boston & Maine** - 3-Dome Tank Car  
30-73272 \$44.95



**Southern** - 3-Dome Tank Car  
30-73275 \$44.95



**Santa Fe** - 3-Dome Tank Car  
30-73274 \$44.95



## Details

- Unit Measures: 10 1/4" x 2 3/8" x 3 9/16"
- Operates On O-27 Curves

# Tank Car



**7UP** - Tank Car  
30-73269 \$49.95

7UP is a trademark of Dr Pepper/Seven Up, Inc., used by M.T.H. Electric Trains under license. ©2008 Dr Pepper/Seven up, Inc.



**Rolling Rock** - Tank Car  
30-73268 \$49.95

"© 2008 Anheuser-Busch, Inc. All Rights Reserved."

## Details

- Unit Measures: 10 3/8" x 2 3/8" 3 13/16"
- Operates On O-27 Curves

**CHROME- PLATED  
FINISH!**



**Caterpillar®** - Tank Car  
30-73270 \$49.95



© 2008 Caterpillar  
CAT, CATERPILLAR, their respective logos, "Caterpillar Yellow" and the POWER EDGE trade dress, as well as corporate and product identity used herein, are trademarks of Caterpillar and may not be used without permission.



**John Deere** - Tank Car  
30-73271 \$49.95

John Deere is a registered trademark of Deere & Company.

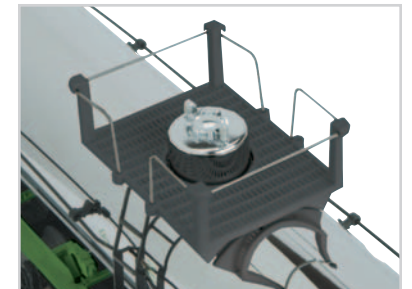

# Husky Stack Car

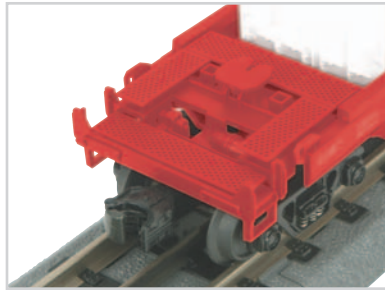

**BNSF** - Husky Stack Car  
30-76319 \$49.95



**Pacer Stacktrain** - Husky Stack Car  
30-76321 \$49.95



**Southern Pacific** - Husky Stack Car  
30-76322 \$49.95



**Maersk** - Husky Stack Car  
30-76320 \$49.95

## Details

- Unit Measures: 14 3/4" x 2 5/16" x 5"
- Operates On O-31 Curves

# Ore Car



**Grand Trunk Western** - Ore Car  
30-75295 \$39.95



**Kansas City Southern** - Ore Car  
30-75296 \$39.95



**Duluth Missabe & Iron Range** - Ore Car  
30-75294 \$39.95



**Ann Arbor** - Ore Car  
30-75293 \$39.95

## Details

- Unit Measures: 7 1/4" x 2 2/2" x 3 1/16"
- Operates On O-27 Curves



# Slag Car



**Harley-Davidson®** - Slag Car  
30-79223 \$47.95



© 2008 H-D, All Rights Reserved.



**Pennsylvania** - Slag Car  
30-79220 \$44.95



**Alaska** - Slag Car  
30-79221 \$44.95



**Bessemer & Lake Erie** - Slag Car  
30-79222 \$44.95



## Details

- Unit Measures: 8 1/4" x 2 1/8" x 3 3/8"
- Operates On O-31 Curves

# Gondola Car with Junk Load



**Union Pacific** - Gondola Car w/Junk Load  
30-72029 \$39.95



**Southern** - Gondola Car w/Junk Load  
30-72028 \$39.95



**Western Maryland** - Gondola Car w/Junk Load  
30-72030 \$39.95



**Boston & Maine** - Gondola Car w/Junk Load  
30-72027 \$39.95

## Details

- Detailed Junk Load
- Unit Measures: 11 15/16" x 2 3/16" x 1 11/16"
- Operates On O-27 Curves

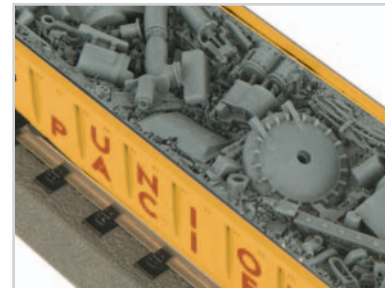

# Gondola Car with LCL Containers



**Grand Trunk Western** - Gondola Car w/LCL Containers  
30-72032 \$42.95



**Jersey Central** - Gondola Car w/LCL Containers  
30-72033 \$42.95



**Canadian National** - Gondola Car w/LCL Containers  
30-72031 \$42.95



**NASA** - Gondola Car w/LCL Containers  
30-72034 \$42.95

## Details

- Removable LCL Containers
- Unit Measures: 11 7/8" x 2 3/16" x 3 1/4"
- Operates On O-27 Curves



# Gondola Car with Crates



**U.S. Navy** - Gondola Car w/Crates  
30-72024 \$44.95



**Ohio State** - Gondola Car w/Crates  
30-72023 \$49.95

Produced by M.T.H. Electric Trains Under License from Ohio State University



**Detroit Toledo & Ironton** - Gondola Car w/Crates  
30-72025 \$44.95



**Pittsburgh & Lake Erie** - Gondola Car w/Crates  
30-72026 \$44.95

## Details

- (3) Removable Crates
- Unit Measures: 11 15/16" x 2 3/16" x 3 1/4"
- Operates On O-27 Curves





# American Crane Car



## Details

- Manually Operated Crane Hook & Boom
- Unit Measures: 17 5/8" x 2 5/8" x 4"
- Operates On O-31 Curves

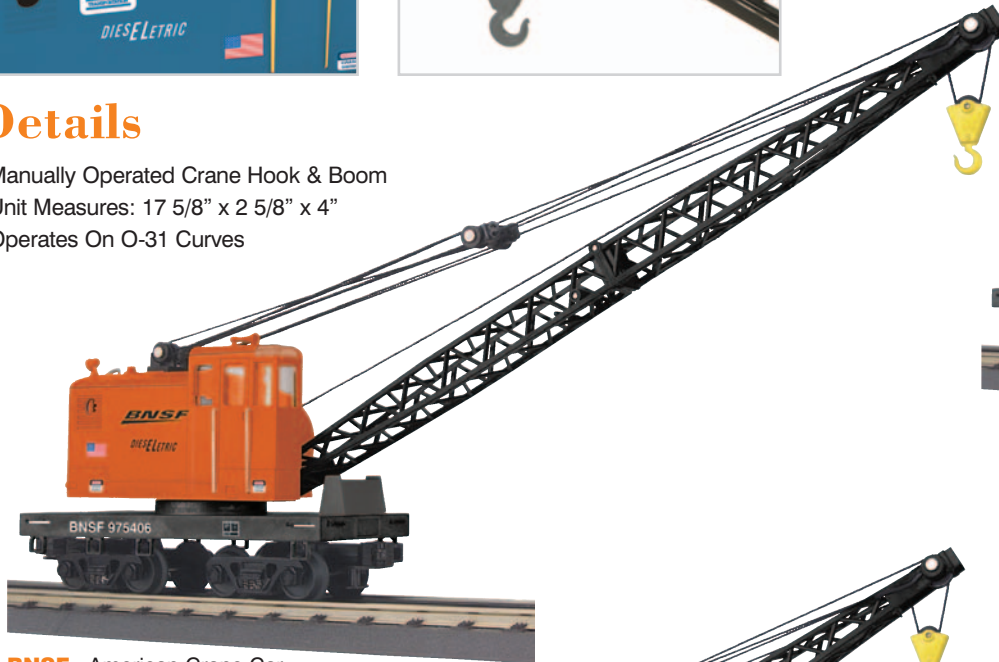

**BNSF** - American Crane Car  
30-79237 \$59.95



**Kansas City Southern** - American Crane Car  
30-79239 \$59.95



**CSX** - American Crane Car  
30-79238 \$59.95



**Norfolk Southern** - American Crane Car  
30-79240 \$59.95

# Center I-Beam Flat Car

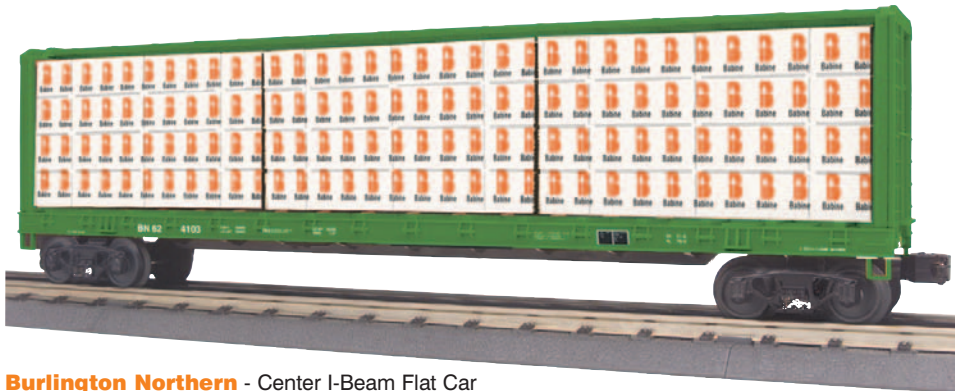

**Burlington Northern** - Center I-Beam Flat Car  
30-76323 \$44.95



**Norfolk Southern** - Center I-Beam Flat Car  
30-76326 \$44.95



**Canadian National** - Center I-Beam Flat Car  
30-76324 \$44.95

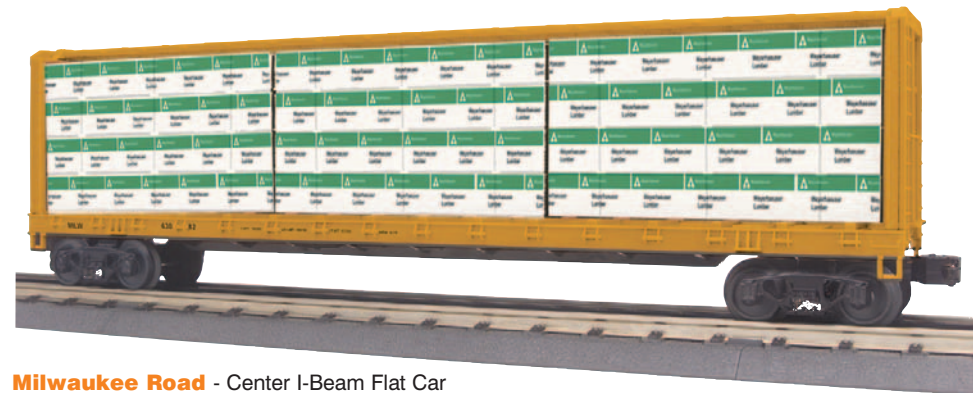

**Milwaukee Road** - Center I-Beam Flat Car  
30-76325 \$44.95

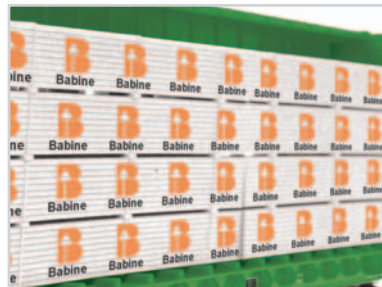

## Details

- Simulated Wood Load
- Unit Measures: 15" x 2 3/8" x 3 15/16"
- Operates On O-31 Curves

## Details

- Flat Cars Measure:  
11 5/8" x 2 1/4" x 3 3/4"
- Auto Carriers Measure:  
11 11/16" x 2 5/16" x 3 1/2"
- Operates On O-27 Curves



**Caterpillar®**  
Flat Car w/(1) CAT 308C CR Hydraulic Excavator Loads  
30-76299 \$59.95

## Flat Car with Load



**John Deere**  
Flat Car w/(2) Model B Tractors  
30-76306 \$59.95



**John Deere**  
Flat Car w/(2) 6420 Tractors  
30-76307 \$59.95

John Deere is a registered trademark of Deere & Company.

**John Deere** - Flat Car w/(2) 5010 Tractors  
30-76308 \$59.95



**Caterpillar®**  
Flat Car w/(2) CAT 906 Compact Wheel Loaders  
30-76298 \$59.95



© 2008 Caterpillar  
CAT, CATERPILLAR, their respective logos, "Caterpillar Yellow" and the POWER EDGE trade dress, as well as corporate and product identity used herein, are trademarks of Caterpillar and may not be used without permission.

## Auto Carrier Flat Car



**Union Pacific**  
Auto Carrier Flat Car  
w/(4) '69 Corvair Monzas  
30-76310 \$59.95



**Wabash**  
Auto Carrier Flat Car w/(4) '37 V8 Convertibles  
30-76309 \$59.95

# Flat Car with Load



**Chesapeake & Ohio** - Flat Car w/(2) '57 Ford Rancheros  
30-76312 \$49.95

**Western Maryland** - Flat Car  
w/(2) '58 Studebaker Golden Hawk Auto Loads  
30-76301 \$49.95



**Ann Arbor** - Flat Car w/(2) Edsel Citations  
30-76311 \$49.95

## Details

- Unit Measures: 11 5/8" x 2 1/4" x 3 3/4"
- Operates On O-27 Curves



**Southern**  
Flat Car w/38' Ahrens Fox VC Fire Truck  
30-76313 \$49.95



**Lehigh Valley**  
Flat Car w/'32 Buffalo Type 50 Fire Truck  
30-76314 \$49.95



**TTX** - Flat Car w/(2) Toyota Land Cruiser VX.R Auto Loads  
30-76300 \$49.95

# Flat Car with Bulkheads and Pipe Load

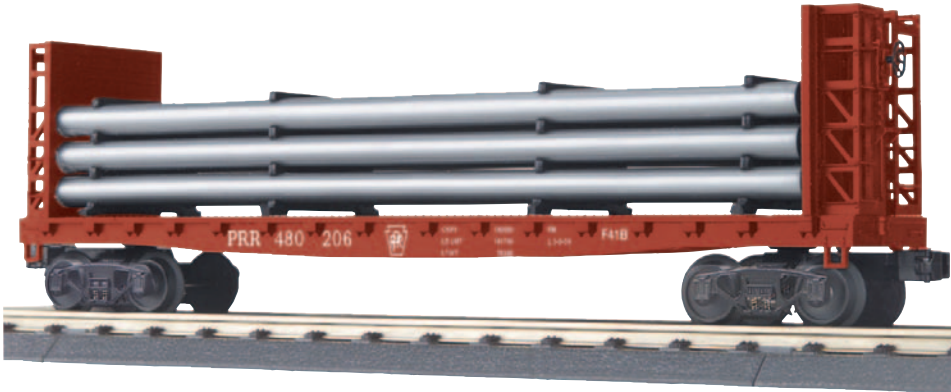

**Pennsylvania** - Flat Car w/Bulkheads & Pipe Load  
30-76318 \$44.95



**Conrail** - Flat Car w/Bulkheads & Pipe Load  
30-76316 \$44.95



**Great Northern** - Flat Car w/Bulkheads & Pipe Load  
30-76317 \$44.95



**Chicago North Western** - Flat Car w/Bulkheads & Pipe Load  
30-76315 \$44.95



## Details

- Pipe Load
- Unit Measures: 13" x 2 3/8" x 3 5/8"
- Operates On O-31 Curves

# Flat Car with Trailer



**Ohio State** - Flat Car w/ Trailer  
30-76305 \$49.95

Produced by M.T.H. Electric Trains Under License from Ohio State University



**Santa Fe** - Flat Car w/ Trailer  
30-76327 \$49.95

## Details

- ABS Detailed Trailer
- Unit Measures: 11 5/8" x 2 1/4" x 3 3/4"
- Operates On O-27 Curves



**Dr Pepper** - Flat Car w/ Trailer  
30-76304 \$49.95

DR PEPPER is a trademark of Dr Pepper/Seven Up, Inc., used by M.T.H. Electric Trains under license. ©2008 Dr Pepper/Seven up, Inc.



**Hires Rootbeer** - Flat Car w/ Trailer  
30-76302 \$49.95

HIRES is a trademark of Dr Pepper/Seven Up, Inc., used by M.T.H. Electric Trains under license. ©2008 Dr Pepper/Seven up, Inc.

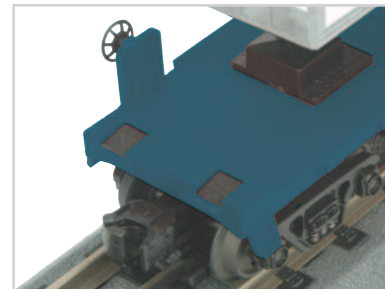

# Steel & Bay Window Caboose



**Chesapeake & Ohio** - Steel Caboose  
30-77158 \$49.95



**Delaware & Hudson** - Steel Caboose  
30-77159 \$49.95



**Northern Pacific** - Steel Caboose  
30-77160 \$49.95



**Coors Light** - Bay Window Caboose  
30-77157 \$59.95

**CHROME  
PLATED!**



**Pittsburg & Shawmut** - Steel Caboose  
30-77161 \$49.95

© 2008 Molson Coors Global Properties, LLC Coors trademarks are properties of Molson Coors Global Properties, LLC, used under license by M.T.H. Electric Trains Limited Edition Adult Collectible-This licensed product is intended for purchase and enjoyment by individuals of legal purchase age for alcohol beverages.

## Details

- Steel Caboose Measures: 9 1/4" x 2 1/2" x 3 7/8"
- Bay Window Caboose Measures: 10 5/8" x 2 3/4" x 3 11/16"
- Operates On O-31 Curves

# Union Pacific Heritage 40' High Cube Box Car



**Southern Pacific** - 40' High Cube Box Car  
30-74504 \$49.95



**Denver Rio Grande** - 40' High Cube Box Car  
30-74501 \$49.95



**Missouri Pacific** - 40' High Cube Box Car  
30-74503 \$49.95







**Western Pacific** - 40' High Cube Box Car  
30-74505 \$49.95



To receive the latest updates on catalog items, sign up for our weekly e-newsletter. Go to the News link at the top of our home page, [www.mthtrains.com](http://www.mthtrains.com).



**Chicago NorthWestern** - 40' High Cube Box Car  
30-74500 \$49.95

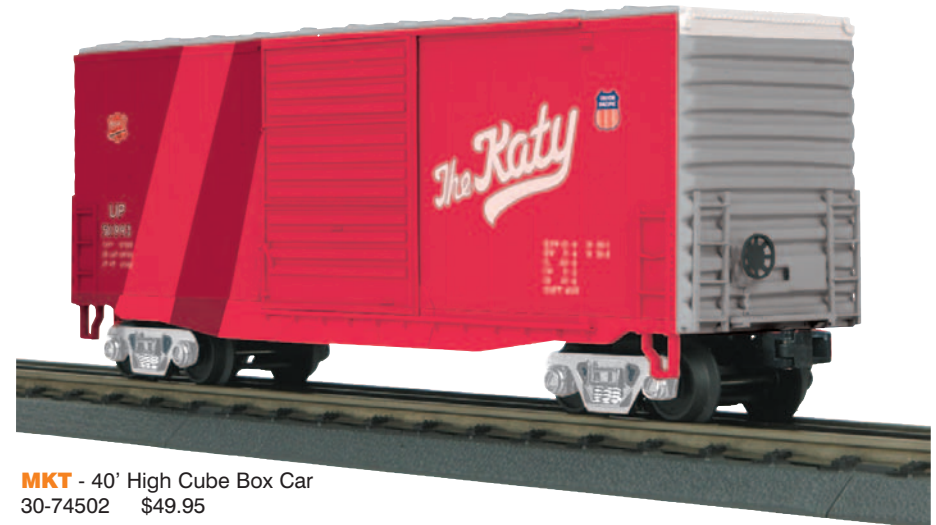

**MKT** - 40' High Cube Box Car  
30-74502 \$49.95

## Details

- Unit Measures: 11 1/2" x 2 3/8" x 2 5/16"
- Operates On O-27 Curves

# Union Pacific Heritage Bay Window Caboose



**Southern Pacific** - Bay Window Caboose  
30-77152 \$54.95



**Denver Rio Grande** - Bay Window Caboose  
30-77156 \$54.95

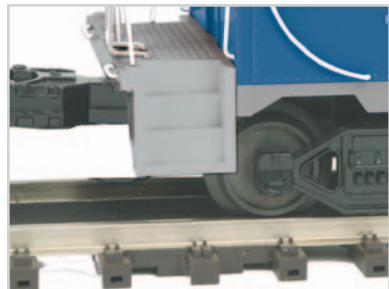

**Missouri Pacific** - Bay Window Caboose  
30-77153 \$54.95



**Western Pacific** - Bay Window Caboose  
30-77155 \$54.95

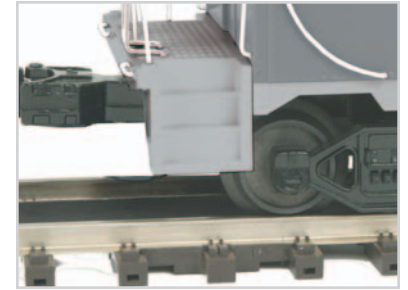

**Chicago NorthWestern** - Bay Window Caboose  
30-77151 \$54.95



**MKT** - Bay Window Caboose  
30-77154 \$54.95

## Details

- Unit Measures: 10 5/8" x 2 3/4" x 3 11/16"
- Operates On O-31 Curves

# Madison Passenger Cars

## Wabash



4-Car 60' Madison Passenger Set  
30-69076 \$199.95



60' Madison Coach Car  
30-69078 \$49.95



2-Car 60' Madison Combo/Diner Set  
30-69077 \$99.95



Erie

2-Car 60' Madison Combo/Diner Set  
30-69068 \$99.95



60' Madison Coach Car  
30-69069 \$49.95



4-Car 60' Madison Passenger Set  
30-69067 \$199.95

## Great Northern



4-Car 60' Madison Passenger Set  
30-69073 \$199.95

## Features

- Durable ABS Intricately Detailed Bodies
- Metal Wheels and Axles
- Overhead Interior Lighting
- Operating Die-Cast Metal Couplers
- Colorful, Attractive Paint Schemes
- End-of-Car Diaphragms
- Fast-Angle Wheel Sets
- Needle-Point Axles
- Detailed Car Interiors
- Die-Cast 6-Wheel Trucks
- 4-Car Sets Feature: (1) Baggage, (2) Coaches, (1) Observation
- Unit Measures: 68 3/4" x 2 5/8" x 3 5/16"
- Operates On O-31 Curves



60' Madison Coach Car  
30-69075 \$49.95



2-Car 60' Madison Combo/Diner Set  
30-69074 \$99.95

## Grand Trunk Western



4-Car 60' Madison Passenger Set  
30-69070 \$199.95



2-Car 60' Madison Combo/Diner Set  
30-69071 \$99.95



60' Madison Coach Car  
30-69072 \$49.95

# Streamlined Passenger Cars

## Great Northern



4-Car 60' Streamlined ABS Passenger Set  
30-67454 \$199.95



2-Car 60' Streamlined ABS Sleeper/Diner  
30-67455 \$99.95



60' Streamlined ABS Full-Length Vista Dome Car  
30-67457 \$54.95



60' Streamlined ABS Coach Car  
30-67456 \$49.95

## Chesapeake & Ohio



60' Streamlined ABS Full-Length Vista Dome Car  
30-67449 \$54.95



2-Car 60' Streamlined ABS Sleeper/Diner  
30-67447 \$99.95



4-Car 60' Streamlined ABS Passenger Set  
30-67446 \$199.95



60' Streamlined ABS Coach Car  
30-67448 \$49.95

## Features

- Durable ABS Intricately Detailed Bodies
- Metal Wheels and Axles
- Overhead Interior Lighting
- Die-Cast 4-Wheel Trucks
- Operating Die-Cast Metal Couplers
- Colorful, Attractive Paint Schemes
- End-of-Car Diaphragms
- Fast-Angle Wheel Sets
- Needle-Point Axles
- Detailed Car Interiors
- 4-Car Sets Feature: (1) Baggage, (1) Coach, (1) Vista Dome, (1) Observation
- Unit Measures: 68 3/4" x 2 5/8" x 3 5/16"
- Operates On O-31 Curves

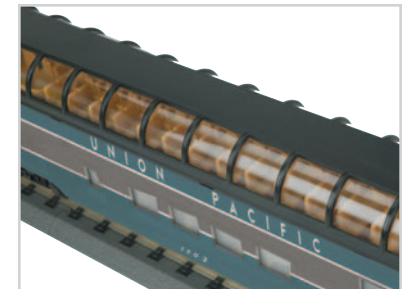
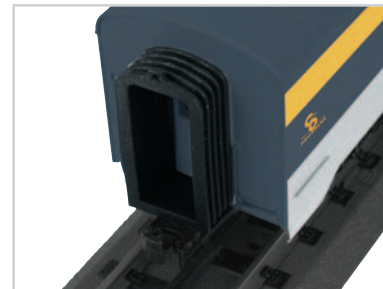

**Delaware & Hudson**



4-Car 60' Streamlined ABS Passenger Set  
30-67450 \$199.95

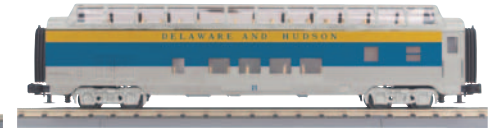

60' Streamlined ABS Full-Length Vista Dome Car  
30-67453 \$54.95



60' Streamlined ABS Coach Car  
30-67452 \$49.95



2-Car 60' Streamlined ABS Sleeper/Diner  
30-67451 \$99.95

**New Haven**



4-Car 60' Streamlined ABS Passenger Set  
30-67462 \$199.95



60' Streamlined ABS Coach Car  
30-67464 \$49.95



2-Car 60' Streamlined ABS Sleeper/Diner  
30-67463 \$99.95



60' Streamlined ABS Full-Length Vista Dome Car  
30-67465 \$54.95

**Santa Fe**



4-Car 60' Streamlined ABS Passenger Set  
30-67466 \$199.95



60' Streamlined ABS Coach Car  
30-67468 \$49.95

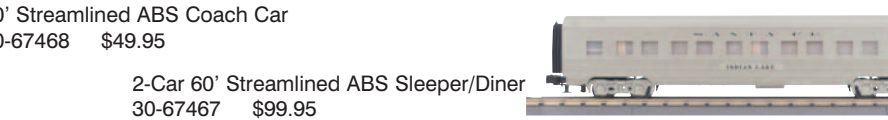

2-Car 60' Streamlined ABS Sleeper/Diner  
30-67467 \$99.95

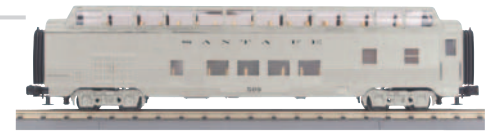

60' Streamlined ABS Full-Length Vista Dome Car  
30-67469 \$54.95

**MKT**

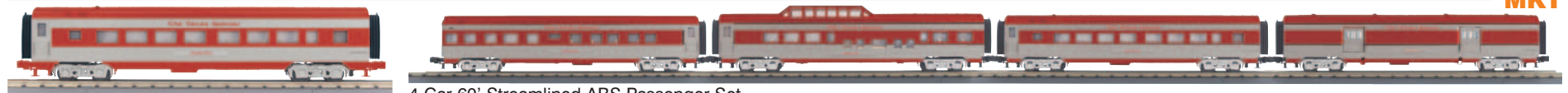

4-Car 60' Streamlined ABS Passenger Set  
30-67458 \$199.95



60' Streamlined ABS Coach Car  
30-67460 \$49.95



2-Car 60' Streamlined ABS Sleeper/Diner  
30-67459 \$99.95



60' Streamlined ABS Full-Length Vista Dome Car  
30-67461 \$54.95

**Union Pacific**



60' Streamlined ABS Coach Car  
30-67472 \$49.95



2-Car 60' Streamlined ABS Sleeper/Diner  
30-67471 \$99.95



60' Streamlined ABS Full-Length Vista Dome Car  
30-67473 \$54.95



60' Streamlined ABS Coach Car  
30-67444 \$49.95



4-Car 60' Streamlined ABS Passenger Set  
30-67442 \$199.95



60' Streamlined ABS Full-Length Vista Dome Car  
30-67445 \$54.95



2-Car 60' Streamlined ABS Sleeper/Diner  
30-67443 \$99.95

**Amtrak**

**Metro Link**



4-Car O-31 SuperLiner Set  
30-6514 \$219.95



2-Car O-31 SuperLiner Coach/Diner Set  
30-6515 \$109.95

SuperLiner Business Class Car  
30-6516 \$54.95



**Souder**



4-Car O-31 SuperLiner Set  
30-6517 \$219.95



SuperLiner Business Class Car  
30-6519 \$54.95



2-Car O-31 SuperLiner Coach/Diner Set  
30-6518 \$109.95



SuperLiner Business Class Car  
30-6513 \$54.95



2-Car O-31 SuperLiner Coach/Diner Set  
30-6512 \$109.95



4-Car O-31 SuperLiner Set  
30-6511 \$219.95

**Features**

- Durable ABS Intricately Detailed Bodies
- Metal Wheels and Axles
- Die-Cast 4-Wheel Trucks
- Overhead Interior Lighting
- Operating Die-Cast Metal Couplers
- Colorful, Attractive Paint Schemes
- End-of-Car Diaphragms
- Fast-Angle Wheel Sets
- Needle-Point Axles
- Detailed Car Interiors
- 4-Car Sets Feature (1) Baggage, (3) Coaches
- Unit Measures:
- Operates On O-31 Curves

**Amtrak**

# ANATOMY OF A PREMIER LOCOMOTIVE

Premier Line engines are full O scale models, 1/48 the size of their prototypes. Because of this, they often require larger radius curves than comparable RailKing models. Premier engines, like the Electro-Motive Diesel SD70ACe shown here, are as detailed as we can reasonably make them, and feature a large number of added-on details. Premier engines also offer more elaborate lighting effects than RailKing models.

Look closely at any Premier Line model and you'll find a combination of superb detailing, prototype accuracy, rugged construction, and smooth, dependable operation that is unmatched by any other manufacturer.



**PREMIER LINE: O SCALE'S FINEST COMBINATION OF**



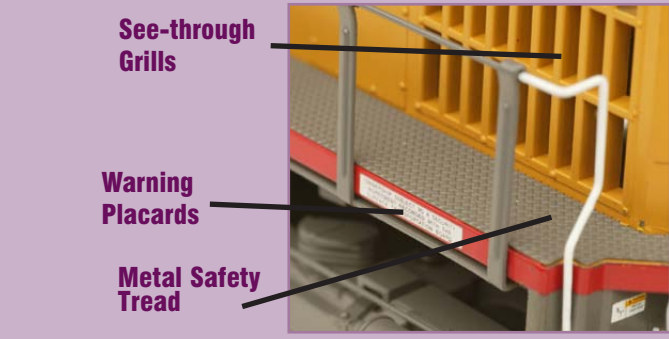

# DETAIL, REALISM AND PERFORMANCE

# 0-6-0 USRA STEAM ENGINE



## Features

- Die-Cast Boiler and Tender Body
- 1:48 Scale Proportions
- Die-Cast Metal Chassis
- Authentic Paint Scheme
- Metal Wheels and Axles
- Constant Voltage Headlight
- Die-Cast Truck Sides
- Engineer and Fireman Figures
- Operating Firebox Glow
- Real Coal Load
- Metal Handrails and Decorative Bell
- Decorative Metal Whistle
- Lighted Cab Interior
- Operating Tender Back-up Light
- Precision Flywheel Equipped Motor
- Locomotive Speed Control In Scale MPH Increments
- Synchronized Puffing ProtoSmoke™ System
- (2) Remote Controlled Proto-Couplers™
- Proto-Scale 3-2™ 3-Rail/2-Rail Conversion Capable
- Wireless Drawbar
- Proto-Sound® 2.0 With The Digital Command System Featuring: Freight Yard Proto-Effects™
- Unit Measures: 17 1/8" x 2 3/8" x 3 5/8"
- Hi-Rail Wheels Operate on O-31 Curves
- Scale Wheels Operate on 18" Radius Curves

During World War I, Uncle Sam nationalized the railroads when they proved unequal to the task of moving massive amounts of men and materiel for the war effort. The agency that ran the trains was the United States Railroad Administration, or USRA, and one of its chief accomplishments was the creation of 12 steam engine designs that lasted for decades. According to the American Society of Mechanical Engineers, USRA locomotives were “the first successful standardization of American motive power” — and the only standard designs until the diesel era.

With 255 engines delivered to 23 railroads, production numbers for the government-issue 0-6-0 were the second-highest of any USRA design. And more than any other USRA engine, the six-coupled switcher was found from coast to coast, from Maine to Texas, and on railroads large and small. Owners were generally quite pleased with the quality of the government’s design, and many 0-6-0s lasted into the 1950s.

Constructed with numerous added-on detail parts, the USRA 0-6-0 sports new Premier line roadnames in 2008. Only M.T.H. offers you this combination of prototype realism and all the operating features you’d want in a steam switcher: smooth, steady operation down to 3 scale miles per hour; remote Proto-Couplers front and rear; chuffing sounds and puffing smoke synchronized with the drivers at a correct four chuffs per revolution; adjustable smoke intensity; great pulling power; directional lighting; and authentic sounds.



**Atlantic Coast Line** - 0-6-0 USRA Steam Engine

20-3304-1	Hi-Rail Wheels	\$599.95
20-3304-2	Scale Wheels	\$599.95



**Nickel Plate Road** - 0-6-0 USRA Steam Engine

20-3306-1	Hi-Rail Wheels	\$599.95
20-3306-2	Scale Wheels	\$599.95



**Union Pacific** - 0-6-0 USRA Steam Engine

20-3307-1	Hi-Rail Wheels	\$599.95
20-3307-2	Scale Wheels	\$599.95



**Missouri Pacific** - 0-6-0 USRA Steam Engine

20-3305-1	Hi-Rail Wheels	\$599.95
20-3305-2	Scale Wheels	\$599.95



**Pennsylvania** - 0-6-0 USRA Steam Engine

20-3280-1	Hi-Rail Wheels	\$599.95
20-3280-2	Scale Wheels	\$599.95



**CB&Q** - 0-6-0 USRA Steam Engine

20-3351-1	Hi-Rail Wheels	\$599.95
20-3351-2	Scale Wheels	\$599.95

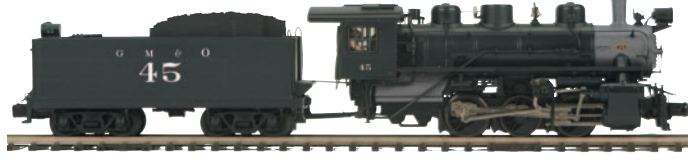

**Gulf Mobile & Ohio** - 0-6-0 USRA Steam Engine

20-3352-1	Hi-Rail Wheels	\$599.95
20-3352-2	Scale Wheels	\$599.95



**Rock Island** - 0-6-0 USRA Steam Engine

20-3354-1	Hi-Rail Wheels	\$599.95
20-3354-2	Scale Wheels	\$599.95



**Texas & Pacific** - 0-6-0 USRA Steam Engine

20-3355-1	Hi-Rail Wheels	\$599.95
20-3355-2	Scale Wheels	\$599.95



**Maine Central** - 0-6-0 USRA Steam Engine

20-3353-1	Hi-Rail Wheels	\$599.95
20-3353-2	Scale Wheels	\$599.95

# 2-8-8-8-2 TRIPLEX STEAM ENGINE



## Features

- Die-Cast Boiler and Tender Body
- Die-Cast Metal Chassis
- Metal Wheels and Axles
- Constant Voltage Headlight
- Die-Cast Truck Sides
- Remote Controlled Proto-Coupler™
- Engineer and Fireman Figures
- Operating Firebox Glow
- Metal Handrails and Decorative Bell
- Decorative Metal Whistle
- Operating Marker Lights
- Lighted Cab Interior
- Precision Flywheel Equipped Motor
- Locomotive Speed Control in Scale MPH Increments
- Wireless Drawbar
- Proto-Scale 3-2™ 3-Rail/2-Rail Conversion Capable
- Synchronized Puffing ProtoSmoke™ System
- Proto-Sound® 2.0 With The Digital Command System Featuring: Freight Yard Proto-Effects™
- Unit Measures: 27 1/4" x 3" x 4 1/4"
- Operates On O-72 Curves



P. T. Barnum would have loved the Triplex. It was an engine of superlatives: more drivers than anything before or since, too big for the shops of its owner, the Erie Railroad, powerful enough to pull a train nearly five miles long. Ninety years ago, in the days before multiple-unit control allowed one throttle to control several locomotives, the Triplex was the ultimate attempt to put as much power as possible in the hands of a single engineer. In the end, it proved a noble, flamboyant, but less-than-successful experiment.

Baldwin Locomotive Works built three triplexes between 1914 and 1916 for pusher service on the Erie Railroad's

daunting Susquehanna Hill (also known as Gulf Summit) near Deposit, N.Y. The cylinders of the Triplex's middle engine were powered by high pressure steam direct from the boiler, while the front and rear engines used low pressure steam exhausted from the middle cylinders.

Each Triplex replaced three ordinary helper engines, and the new locomotives worked well enough to stay on the Erie roster for more than a decade. But the design proved a bit over the top and only one more Triplex was ever built, for the Virginian Railway. Even with their huge boilers, the locomotives could only make enough steam to go 10 mph. One reason was poor draft in the firebox,

because only the front cylinders exhausted through the smokebox and created draft; the rear cylinders exhausted through a separate smokestack on the tender. Another inherent problem with the design was that traction from the rear engine decreased as the boiler used coal and water and the tender got lighter.

### Did You Know?

The Triplex was engineered to haul 640 fifty-ton cars in a train almost five miles long. But the couplers and draft gear of the early twentieth century could not have handled such a load, so the 2-8-8-8-2 was used as a pusher and never put to a full test.



**Erie (Black)** - 2-8-8-8-2 Triplex Steam Engine  
20-3361-1 Hi-Rail Wheels \$1399.95



**Virginian** - 2-8-8-8-2 Triplex Steam Engine  
20-3362-1 Hi-Rail Wheels \$1399.95

**Erie (Russian Iron)** - 2-8-8-8-2 Triplex Steam Engine Freight Set  
20-3360-1 w/Proto-Sound 2.0 \$1499.95



# PRINCESS CORONATION STEAM ENGINE

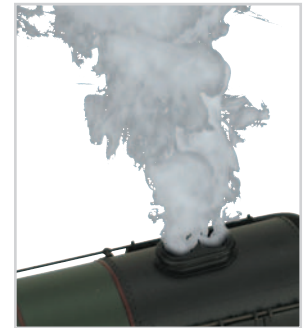

## Features

- Die-Cast Boiler and Tender Body
- 1:43.5 Scale Proportions
- Die-Cast Metal Chassis
- Authentic Paint Scheme
- Metal Wheels and Axles
- Constant Voltage Headlight
- Die-Cast Truck Sides
- Real Coal Load
- Precision Flywheel Equipped Motor
- Supplied With Remotely Controlled Proto-Coupler™ and European Hook Coupler As Well
- Engineer and Fireman Figures
- Operating Firebox Glow
- Metal Handrails and Decorative Bell
- Decorative Metal Whistle
- Lighted Cab Interior
- Locomotive Speed Control
- Proto-Scale 3-2™ 3-Rail/2-Rail Conversion Capable
- Synchronized Puffing ProtoSmoke™ System
- Wireless Drawbar
- Proto-Sound® 2.0 With The Digital Command System Featuring: Passenger Station Proto-Effects™
- Unit Measures: 23 7/16" x 2 11/16" x 4 5/16"
- Hi-Rail Wheels Operate on O-54 Curves
- Scale Wheels Operate on 42" Radius Curves

## Did You Know?

The Railways Act of 1921 mandated the merger of Britain's myriad railways into four companies in 1923: the London, Midland & Scottish Railway (LMS), the London & North Eastern Railway (LNER), the Great Western Railway (GWR), and the Southern Railway (SR). In 1948, these four companies were nationalized to form British Railways.

In the years before World War II, Londoners had at least two ways to get to Scotland in style. From Kings Cross, one could speed up the East Coast main to Edinburgh on the LNER's Flying Scotsman, behind one of Nigel Gresley's handsome Pacifics — perhaps a streamlined A4 or maybe an older, apple-green A3. Or one could depart instead from Euston station on the LMS and fly northward to Glasgow on the Coronation Scot or the Royal Scot, behind the most powerful steam locomotives in the land: William Stanier's Princess Coronation Class 4-6-2's.

While the London, Midland & Scottish was the largest of England's four major railways, its motive power department had been hobbled by internal rivalries, a legacy from the several railways that combined in 1923 to form the LMS. Locomotive designer William Stanier, with a direct line to the president of the railroad, was hired in 1932 to resolve those problems. He brought the LMS from an also-ran to a leader in British engine design. Stanier's crowning achievement was the four-cylinder Princess Coronation Class Pacifics, built from 1937-1948. In contrast with American designers, who generally shunned engines with more than two cylinders as being too hard to maintain, Europeans often used three or four cylinders to produce a more balanced engine that was easier on the track. In Stanier's design, the Walschaert's valve gear on the outside cylinders also drove the valves on the inside cylinders, located within the frame, through a set of rocker arms.

To Stanier's chagrin, the first examples of the class wore a streamlined shroud to match the Coronation Scot train they were designed to haul. Various described as an upside-down bathtub or a sausage, the streamlining was omitted on later engines in the class, revealing muscular lines that looked particularly handsome in LMS crimson lake livery with gilt lining. In the British tradition, all of these passenger engines were named. No. 6234, Duchess of Abercorn, set an all-time record for British steam when she recorded 3,300 horsepower in February 1939.

Relive the glory days of LMS express passenger service with our superbly detailed Princess Coronation Class Pacific, complete with sounds recorded from the prototype Duchess of Sutherland, and synchronized puffing smoke with a correct eight chuffs per driver revolution.



**NEW!** British Railways - Princess Coronation Duchess of Hamilton Steam Engine  
 20-3369-1 Hi-Rail Wheels \$1199.95  
 20-3369-2 Scale Wheels \$1199.95



**NEW!** British Railways - Princess Coronation City of London Steam Engine  
 20-3370-1 Hi-Rail Wheels \$1199.95  
 20-3370-2 Scale Wheels \$1199.95



**NEW!** British Railways - Princess Coronation Stoke-on-Trent Steam Engine  
 20-3371-1 Hi-Rail Wheels \$1199.95  
 20-3371-2 Scale Wheels \$1199.95



**NEW!** London, Midland and Scottish Railway - Princess Coronation City of Leicester Steam Engine  
 20-3367-1 Hi-Rail Wheels \$1199.95  
 20-3367-2 Scale Wheels \$1199.95



**NEW!** London, Midland and Scottish Railway - Princess Coronation Duchess of Sutherland Steam Engine  
 20-3368-1 Hi-Rail Wheels \$1199.95  
 20-3368-2 Scale Wheels \$1199.95

#### Learn More About It

Search on the item number for this model on the M.T.H. Web site for links to additional information on this locomotive and prototype British railroading.

# 4-8-4 "J" STEAM ENGINE



## Features

- Die-Cast Boiler and Tender Body
- Die-Cast Metal Chassis
- Authentic Paint Scheme
- Metal Wheels and Axles
- Constant Voltage Headlight
- Die-Cast Truck Sides
- Precision Flywheel Equipped Motor
- Remote Controlled Proto-Coupler™
- Engineer and Fireman Figures
- Operating Firebox Glow
- Metal Handrails and Decorative Bell
- Decorative Metal Whistle
- Operating Marker Lights
- Lighted Cab Interior
- Synchronized Puffing ProtoSmoke™ System
- Operating Tender Back-up Light
- Locomotive Speed Control in Scale MPH Increments
- 1:48 Scale Proportions
- Proto-Scale 3-2™ 3-Rail/2-Rail Conversion Capable
- Wireless Drawbar
- Proto-Sound® 2.0 With The Digital Command System Featuring: Freight Yard or Passenger Station Proto-Effects™
- Unit Measures: 27 3/4" x 2 3/4" x 3 7/8"
- Hi-Rail Wheels Operate on O-42 Curves
- Scale Wheels Operate on 42" Radius Curves



The Norfolk & Western was renowned, perhaps better than any other railroad, for its steam power efficiency and no locomotive better exemplified this than the J Class Northern. Debuting in 1941, the 4-8-4 rolled onto the rails with its beautiful streamlined cowling gracing an incredibly powerful and efficient powerplant.

Developed to meet the growing passenger service requirements leading up to and through World War II, the J Class locomotives were powerful and more than capable of tackling the grades of the Blue Ridge mountains. Yet, they could "run like a rabbit" on the flats, easily reaching speeds greater than 100 miles per hour with 12 to 14 passenger cars in tow. Even with the decline in passenger service after the war, the N&W added more J's to their fleet and created some of the country's most elegant passenger service runs. Famous trains like the Powhatan Arrow were renowned for their amenities and service. Despite the growing rise of dieselization, the J Class locomotives were able to remain in service until 1959, longer than any other major railroad's use of steam power.



**Norfolk & Western** - 4-8-4 "J" Steam Engine  
 20-3363-1 Hi-Rail Wheels \$1099.95  
 20-3363-2 Scale Wheels \$1099.95



**Norfolk & Western** - 4-8-4 "J" Steam Engine  
 20-3364-1 Hi-Rail Wheels \$1099.95  
 20-3364-2 Scale Wheels \$1099.95

To receive the latest updates on catalog items, sign up for our weekly e-newsletter. Go to the News link at the top of our home page, [www.mthtrains.com](http://www.mthtrains.com).



**Norfolk & Western** - 4-8-4 "J" Passenger Set  
 20-3365-1 w/Proto-Sound 2.0 \$1199.95



**Norfolk & Western** - 4-8-4 "J" Express Mail Freight Set  
 20-3366-1 w/Proto-Sound 2.0 \$1199.95

# 4-6-0 CAMELBACK STEAM ENGINE



## Features

- Die-Cast Boiler and Tender Body
- 1:48 Scale Proportions
- Die-Cast Metal Chassis
- Authentic Paint Scheme
- Metal Wheels and Axles
- Constant Voltage Headlight
- Die-Cast Truck Sides
- Real Coal Load
- Precision Flywheel Equipped Motor
- Remote Controlled Proto-Coupler™
- Engineer and Fireman Figures
- Operating Firebox Glow
- Metal Handrails and Decorative Bell
- Decorative Metal Whistle
- Lighted Cab Interior
- Locomotive Speed Control in Scale MPH Increments
- Proto-Scale 3-2™ 3-Rail/2-Rail Conversion Capable
- Synchronized Puffing ProtoSmoke™ System
- Wireless Drawbar
- Proto-Sound® 2.0 With The Digital Command System Featuring: Passenger Station Proto-Effects™
- Unit Measures: 17 3/4" x 2 1/2" x 4 1/8"
- Hi-Rail Wheels Operate on O-31 Curves
- Scale Wheels Operate on 42" Radius Curves

Coal is coal, right? Not exactly. Early steam engines burned wood in part because the common coal of the time, rock-hard anthracite, burned too slow for use in locomotives. The discovery of vast reserves of softer, faster-burning bituminous coal in the mid-1800s began the switch to coal as America's primary locomotive fuel. Anthracite, meanwhile, which burns with a smaller flame and little smoke, gained widespread use for home heating.

But one characteristic of anthracite mining was that close to 20% of production wound up as finely-ground, low-quality waste, or culm, that accumulated in huge heaps outside the mines. In the 1870s, John E. Wooten of the Philadelphia & Reading Rail Road determined to explore the potential of culm as a cheap locomotive fuel. The result was the Wooten firebox, based on a large grate, or firebox floor, two to three times the size of a conventional grate and burning culm in a very thin layer. Whereas most engines of the time had a narrow firebox placed between the rear drivers, the Wooten firebox extended out over the drivers and was as wide as clearances allowed. This, of course, made space in the cab rather tight, and designers soon moved the cab forward and placed it over the boiler barrel, which was smaller in diameter than the Wooten firebox. The result was the Camelback or "Mother Hubbard" style of locomotive, with the engineer in the cab and the fireman back on the tender deck shoveling culm into the rear of the engine. By the late 1800s more than 40 roads rostered Mother Hubbards; among the largest users were the New York Ontario & Western, the Jersey Central, and its parent the Reading.

British author Brian Reed noted in *Locomotives in Profile* that "Firing a Mother Hubbard was no kind of job at all. The tallow-pot [fireman] was alone, and he had almost no range of vision. He could see the driving cab and the line ahead only if he hung well out sideways, and ... it was difficult for him to determine if there was anything wrong in the cab... With the tender bucketing along behind the engine with a most decided motion of its own, he had to shovel up to two tons of culm an hour from one vehicle to another." No wonder that safety concerns led the Interstate Commerce Commission to ban the construction of new Mother Hubbards in 1918.

New for 2008, our Premier Mother Hubbard replicates the Central Railroad of New Jersey's Class L8s 780-series 4-6-0s, the Jersey Central's final group of camelbacks. Although not a favorite of crews, these 1918 Baldwin products were remarkably long-lived workhorses, serving as fast freight and later as commuter engines until the end of steam in 1954.

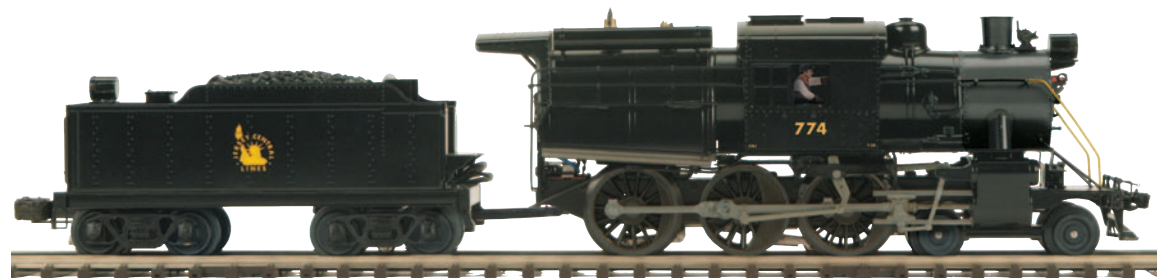

**NEW!** Jersey Central (1955 Railfan Trip) - 4-6-0 Camelback Steam Engine  
 20-3356-1 Hi-Rail Wheels \$899.95  
 20-3356-2 Scale Wheels \$899.95



**NEW!** Jersey Central - 4-6-0 Camelback Steam Engine  
 20-3357-1 Hi-Rail Wheels \$899.95  
 20-3357-2 Scale Wheels \$899.95



**NEW!** New York Ontario & Western - 4-6-0 Camelback Steam Engine  
 20-3358-1 Hi-Rail Wheels \$899.95  
 20-3358-2 Scale Wheels \$899.95



**NEW!** Reading - 4-6-0 Camelback Steam Engine  
 20-3359-1 Hi-Rail Wheels \$899.95  
 20-3359-2 Scale Wheels \$899.95



# 2-10-0 RUSSIAN DECAPOD STEAM ENGINE



## Features

- Die-Cast Boiler and Tender Body
- 1:48 Scale Proportions
- Die-Cast Metal Chassis
- Authentic Paint Scheme
- Metal Wheels and Axles
- Constant Voltage Headlight
- Die-Cast Truck Sides
- Real Coal Load
- Precision Flywheel Equipped Motor
- Remote Controlled Proto-Coupler
- Engineer and Fireman Figures
- Operating Firebox Glow
- Metal Handrails and Decorative Bell
- Decorative Metal Whistle
- Operating Marker Lights
- Lighted Cab Interior
- Operating Tender Back-up Light
- Locomotive Speed Control In Scale MPH Increments
- Proto-Scale 3-2™ 3-Rail/2-Rail Conversion Capable
- Synchronized Puffing ProtoSmoke™ System
- Wireless Drawbar
- Proto-Sound® 2.0 With The Digital Command System Featuring: Freight Yard Proto-Effects™
- Unit Measures: 20" x 2 3/4" x 4 5/5"
- Hi-Rail Wheels Operate on O-72 Curves
- Scale Wheels Operate on 54" Radius Curves

There are two reasons to put a lot of drivers under a locomotive. One, obviously, is to increase pulling power. The other is to spread out the engine's weight, allowing it to operate on lighter-duty track and rail. The "Russian" decapods were an example of the latter.

During World War I, the Imperial Russian State Railways ordered 1230 locomotives of the 2-10-0 wheel arrangement from Alco and Baldwin. With light axle loading and tiny 52" drivers — about the same size as a typical switcher — these decapods were designed for moderate speeds on light and often poorly maintained track. When the Bolshevik Revolution overthrew the czar, the final 200 engines in the order were stranded in the U.S. Desperately in need of wartime motive power, the United States Railroad Administration (USRA) had the decapods regauged from five feet to standard gauge and allocated them to railroads throughout the east in early 1918.

While the 2-10-0 wheel arrangement was not especially popular in North America, the light-footed, nimble, yet strong Russian decapods proved ideal for service on branch lines and smaller railroads. Although originally allocated mainly to larger class 1 railroads including the Pennsy, Erie, Western Maryland, Southern, New Haven, and Atlantic Coast Line, many were later sold to smaller railroads where they became the largest motive power on the road. A number of Russian decapods served to the end of steam, and six are preserved today.

For a lot of action in a small steamer, add this vest-pocket decapod to your railroad. New for 2008, our model features the extraordinary detail you've come to expect in a Premier locomotive, plus all the features that make Proto-Sound 2.0 locomotives more fun to operate than any other engines in model railroading — including synchronized, puffing smoke with variable intensity; CD-quality sound; and Proto-Speed control for smooth pulling power at any speed from 3 mph to full throttle.



**Erie** - 2-10-0 Russian Decapod Steam Engine  
 20-3309-1 Hi-Rail Wheels \$999.95  
 20-3309-2 Scale Wheels \$999.95



**Pittsburgh Shawmut & Northern** - 2-10-0 Russian Decapod Steam Engine  
 20-3310-1 Hi-Rail Wheels \$999.95  
 20-3310-2 Scale Wheels \$999.95



**Western Maryland** - 2-10-0 Russian Decapod Steam Engine  
 20-3311-1 Hi-Rail Wheels \$999.95  
 20-3311-2 Scale Wheels \$999.95



**Atlantic Coast Line** - 2-10-0 Russian Decapod Steam Engine  
 20-3308-1 Hi-Rail Wheels \$999.95  
 20-3308-2 Scale Wheels \$999.95

# 4-6-4 ROYAL HUDSON STEAM ENGINE



## Features

- Die-Cast Boiler and Tender Body
- 1:48 Scale Proportions
- Die-Cast Metal Chassis
- Authentic Paint Scheme
- Metal Wheels and Axles
- Constant Voltage Headlight
- Die-Cast Truck Sides
- Precision Flywheel Equipped Motor
- Remote Controlled Proto-Coupler™
- Engineer and Fireman Figures
- Operating Firebox Glow
- Metal Handrails and Bell
- Decorative Metal Whistle
- Operating Marker Lights
- Lighted Cab Interior
- Operating Tender Back-up Light
- Locomotive Speed Control In Scale MPH Increments
- Proto-Scale 3-2™ 3-Rail/2-Rail Conversion Capable
- Synchronized Puffing ProtoSmoke™ System
- Wireless Drawbar
- Proto-Sound® 2.0 With The Digital Command System Featuring: Passenger Station Proto-Effects™
- Unit Measures: 24" x 2 1/2" x 4"
- Hi-Rail Wheels Operate On O-42 Curves
- Scale Wheels Operate on 42" Radius Curves

In 1939 King George VI, accompanied by his wife Queen Elizabeth, became the first reigning British monarch to visit Canada. For 31 days Their Majesties toured their Canadian Dominion from coast to coast in a 12-car train described by the Canadian Pacific as "regal in appearance, luxurious in interior decorations and appointments," and "in every way a home and a castle." The King, being something of a railroad buff, occasionally rode in the cab, and after one such cab ride the Queen was heard to remark, "That was a thrilling experience." The Canadian National used four different locomotives to handle the eastbound leg of the trip. The Canadian Pacific, however, handled its 3,224-mile westbound leg with a single locomotive, streamlined Hudson No. 2850, except for some assistance over mountain passes. In recognition of 2850's flawless performance, the Canadian Pacific was granted permission to designate its entire class of streamlined Hudsons as "Royal Hudsons," with the engines wearing the royal family crown on their running boards. If ever a locomotive was granted knighthood, this was it.

New for 2008, the Canadian Pacific Royal Hudson joins the Premier lineup in four authentic paint schemes. Engine 2850 wears the blue livery and royal coats of arms applied for their Majesties visit. Authentic, matching cars with royal crowns and coats of arms are listed in the Premier passenger car section, including the multiple observation cars used on the actual train. Hudson 2851 led the pilot train that preceded the royal train on its journey, bearing members of the press and other personnel. Correct cars for the pilot train are also offered. Engine 2839 was retired by the CP in 1960 and restored for service in the Southern Railway's steam program, where it hauled excursions in the late 1970s and early 1980s and performed in the movie *Coal Miner's Daughter*. Restored once again, it resides today in the Nethercutt Collection Museum in San Sylmar, California. Royal Hudson 2860 became a tourist icon of British Columbia, leading steam excursions for 25 years until a forced retirement in 1999. Restored in 2006, it steams today at West Coast Railway Heritage Park in Squamish, BC.



**British Columbia** - 4-6-4 Royal Hudson Steam Engine

20-3312-1	Hi-Rail Wheels	\$999.95
20-3312-2	Scale Wheels	\$999.95



**Canadian Pacific** - 4-6-4 Royal Hudson Steam Engine

20-3313-1	Hi-Rail Wheels	\$999.95
20-3313-2	Scale Wheels	\$999.95



**Southern** - 4-6-4 Royal Hudson Steam Engine

20-3314-1	Hi-Rail Wheels	\$999.95
20-3314-2	Scale Wheels	\$999.95



**Canadian Pacific (Royal Tour 1939)** - 4-6-4 Royal Hudson Steam Engine

20-3315-1	Hi-Rail Wheels	\$999.95
20-3315-2	Scale Wheels	\$999.95

#### Learn More About It

On the MTH Web site, do a Product Search on any Royal Hudson item number, and you'll find a link to additional information on this engine.

# 2-3-1E CHAPELON PACIFIC STEAM ENGINE

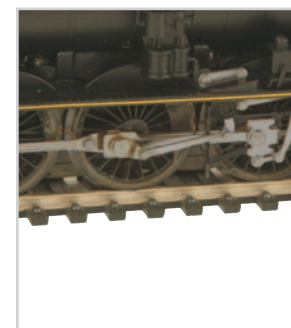

## Features

- Die-Cast Boiler and Tender Body
- 1:43.5 Scale Proportions
- Die-Cast Metal Chassis
- Authentic Paint Scheme
- Metal Wheels and Axles
- Constant Voltage Headlight
- Die-Cast Truck Sides
- Precision Flywheel Equipped Motor
- Engineer and Fireman Figures
- Operating Firebox Glow
- Metal Handrails and Bell
- Metal Whistle
- Supplied With Remotely Controlled Proto-Coupler™ and European Hook Coupler As Well
- Lighted Cab Interior
- Real Coal Load
- Locomotive Speed Control In Scale MPH Increments
- Proto-Scale 3-2™ 3-Rail/2-Rail Conversion Capable
- Synchronized Puffing ProtoSmoke™ System
- Wireless Drawbar
- Proto-Sound® 2.0 With The Digital Command System Featuring: Passenger Station Proto-Effects™
- Unit Measures: 23 1/4" x 20 5/8" x 4"
- Hi- Rail Wheels Operate On O-54 Curves
- Scale Wheels Operate on 42" Radius Curves



In the late 1800s, train travel across Europe was a messy affair. At each national border, passengers got off one train, walked across the border, and climbed aboard another. Like George Pullman in the United States, Belgian George Nagelmackers dreamed of something better: a rolling hotel in which travelers could sleep, eat, and relax from one end of their journey to the other. In 1883, the Orient Express made the dream a reality: a single train from Paris to Romania (and within a few years, from Paris to Istanbul), with rolling stock supplied by Nagelmackers' Compagnie Internationale des Wagons-Lits et Grandes Express Europeens ("wagon-lit" being French for sleeping car). Only the locomotives were changed as the Orient Express rolled across no less than seven national borders on its three-day journey.

From 1889 to 1977, with interruptions for two world wars, the Orient Express ran from Gare de l'Est station in Paris to Sirkeci Terminal on the Golden Horn, the gateway to Asia. After the 12-mile-long Simplon Tunnel was opened under the Alps, a second, more southerly route was added in 1919: the Simplon Orient Express via Milan, Venice, and Trieste. The train, of course, got caught up in the politics of the regions through which it ran and became a setting for international intrigue, mystery, and romance—more so in fiction than in fact. The Orient Express' screen credits include the James Bond film *From Russia With Love* and, most famously, movie and print versions of Agatha Christie's 1934 novel *Murder on the Orient Express*. The long, dark passage through the Simplon Tunnel, of course, has been a favorite setting for nefarious events.

Add a touch of color, mystery, and intrigue (but hopefully not murder) to your own railroad with our first-ever M.T.H. model of a European prototype. This engine replicates the French Chapelon Pacific (2-3-1 wheel arrangement in French parlance, which counts axles rather than wheels) that hauled the Orient Express from Paris to the French border in the period between the world wars. The sound set in this fully-featured Premier model includes a European whistle and station announcements in English and French.



**Orient Express** - 2-3-1E Chapelon Pacific Steam Engine

20-3343-1	Hi-Rail Wheels	\$999.95
20-3343-2	Scale Wheels	\$999.95



**Fleche D'Or** - 2-3-1E Chapelon Pacific Steam Engine

20-3345-1	Hi-Rail Wheels	\$999.95
20-3345-2	Scale Wheels	\$999.95

**ADD A MATCHING PASSENGER SET!**

See Page 154



**Orient Express** - 2-3-1E Chapelon Pacific Steam Engine

20-3344-1	Hi-Rail Wheels	\$999.95
20-3344-2	Scale Wheels	\$999.95

To view a 4-page brochure on the Chapelon Pacific, the Orient Express, and the Fleche d'Or, search on the item number for any of these engines on [www.mthtrains.com](http://www.mthtrains.com).





# SD70ACE/SD70M-2 DIESEL ENGINE



## Features

- Intricately Detailed ABS Body
- Die-Cast Truck Sides, Pilots and Fuel Tank
- Colorful Paint Scheme
- Metal Chassis
- Metal Handrails and Decorative Horn
- (2) Cab Figures
- Moveable Roof Fan Blades
- Metal Body Side Grilles
- Directionally Controlled Headlights
- Metal Wheels, Axles and Gears
- (2) Remotely Controlled Proto-Couplers™
- (2) Precision Flywheel Equipped Motors
- Locomotive Speed Control
- Lighted Cab Interior
- Illuminated Number Boards
- Lighted Marker Lights
- Operating Ditch Lights
- Operating Smoke Unit
- Proto-Scale 3-2™ 3-Rail/2-Rail Conversion Capable
- Proto-Sound® 2.0 With The Digital Command System Featuring: Freight Yard Proto-Effects™
- Unit Measures: 18 1/2" x 2 5/8" x 4"
- Hi- Rail Wheels Operate On O-42 Curves
- Scale Wheels Operate on 42" Radius Curves

**ADD MATCHING  
HOPPER SETS!**

See Pages 150-151

The SD70ACe is Electro-Motive Division's hope for the future. While designed to meet the Environmental Protection Agency's Tier-2 emissions requirements that took effect on January 1, 2005, this replacement of the SD70MAC also seems to have a higher purpose: to recapture the lead in North American locomotive sales that EMD lost to General Electric in 1987.

Under the hood beats a third-generation model 710 diesel with 4300 horsepower; only slight modifications were needed to make the model 710 meet new emission standards. With 5000 such motors in service worldwide and a reputation for dependability, EMD reasoned that shop crews would prefer familiar technology.

Other than the prime mover, however, virtually every element of the SD70ACe has been re-thought to create a 21st century locomotive. Ergonomics were a prime con-

sideration. The engine's angular nose offers the crew far better visibility than most other locomotives, and the cab is comfortable for engineers of almost any size. Digital screens provide a range of information on what is happening both inside the locomotive and out on the road. The cab easily accommodates a crew of three - an important factor in a modern world without cabooses. And there is, of course, a cupholder for the engineer.

The SD70ACe also offers, in EMD's words, "outstanding improvements in maintainability." All electrical wires are on the right side of the locomotive and all piping is on the left, with most pipes and wires routed under the frame so they can be serviced by a man standing outside the engine — rather than crawling around at the bottom of the engine room. The number of electrical components has been drastically reduced while access to the remaining parts has been seriously improved. And the time

between service intervals has been doubled, from every three months to every six months.

After a year of testing on the road and at the Association of American Railroads' test track in Pueblo, CO, the first SD70ACe's ("e" stands for "enhanced") were delivered to CSX Transportation in 2004. At the present time, mainline American railroads generally maintain dual fleets of locomotives. AC power is used for heavy coal hauling and hotshot intermodal traffic because AC traction motors offer higher starting tractive effort with the same horsepower. Less expensive, traditional DC power is used for more mundane duties. But with the SD70ACe, Electro-Motive hopes it may have the 21st Century successor to its 1949 Geep - a locomotive that can be nearly all things to all railroads.



<b>Norfolk Southern</b> - SD70M-2 Diesel Engine		
20-2920-1	Hi-Rail Wheels	\$429.95
20-2920-2	Scale Wheels	\$449.95
20-2920-3	Non-Powered	\$199.95



<b>Canadian National</b> - SD70M-2 Diesel Engine		
20-2919-1	Hi-Rail Wheels	\$429.95
20-2919-2	Scale Wheels	\$449.95
20-2919-3	Non-Powered	\$199.95

## POWERED UNITS AVAILABLE IN THREE ROAD NUMBERS



<b>Union Pacific</b> - SD70ACe Diesel Engine		
20-2918-1	Hi-Rail Wheels	\$429.95
20-2918-2	Scale Wheels	\$449.95
20-2918-3	Non-Powered	\$199.95



<b>BHP</b> - SD70ACe Diesel Engine		
20-2916-1	Hi-Rail Wheels	\$429.95
20-2916-2	Scale Wheels	\$449.95
20-2916-3	Non-Powered	\$199.95



<b>Kansas City Southern</b> - SD70ACe Diesel Engine		
20-2917-1	Hi-Rail Wheels	\$429.95
20-2917-2	Scale Wheels	\$449.95
20-2917-3	Non-Powered	\$199.95



# EMD GP35 DIESEL ENGINE

## Features

- Directionally Controlled Headlights
- Intricately Detailed ABS Body
- Metal Wheels, Axles and Gears
- Die-Cast Truck Sides, Pilots and Fuel Tank
- (2) Remotely Controlled Proto-Couplers™
- Colorful Paint Scheme
- Metal Chassis
- Metal Handrails and Horn
- (2) Precision Flywheel Equipped Motors
- Locomotive Speed Control In Scale MPH Increments
- Proto-Scale 3-2™ 3-Rail/2-Rail Conversion Capable
- Lighted Cab Interior
- Illuminated Number Boards
- Lighted Marker Lights
- (2) Engineer Cab Figures
- Moveable Roof Fan Blades
- Metal Body Side Grilles
- Operating Smoke Unit
- Proto-Sound® 2.0 With The Digital Command System Featuring: Freight Yard Proto-Effects™
- Unit Measures: 17 1/2" x 2 1/2" x 4 5/16"
- Hi- Rail Wheels Operate On O-31 Curves
- Scale Wheels Operate on 42" Radius Curves

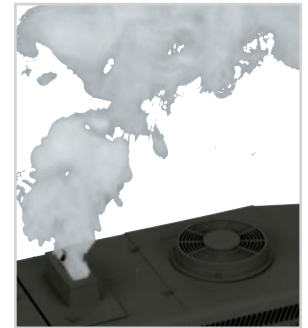

Produced from 1963 to 1966, the GP35, along with its six-axle SD35 sibling, marked both an end and a beginning. They were the last road diesels to use the EMD 567 motor that had powered switchers, F-units, and Geeps since 1939 (so named because each cylinder displaced 567 cubic inches). For the horsepower race of the 1960s, EMD tweaked the 567 to a turbocharged V-16 delivering 2500 hp. That was it for the 567, however, and in 1966 the baton was passed to the more powerful model 645. But while the "35 line" diesels ushered out an old motor, they inaugurated a new look. Their angled cab roofs and the clean, squared-off lines of their car bodies established the look of EMD power for the next three decades.

Introduced to compete with General Electric's landmark U25B, which had ushered in the second generation of diesel power, the GP35 outsold the "U-Boat" nearly three to one. There was a strong market for new power in the mid-1960s because the first-generation diesels that had vanquished steam were wearing out. While first-generation rosters had often been a hodgepodge of manufacturers and models as railroads experimented with the new technology, by 1960 Alco, EMD, and GE were the only manufacturers left standing — and Alco would soon throw in the towel. As a result, virtually every major U.S. railroad became a GP35 customer and over 1300 engines were sold in the United States, Canada, and Mexico.

While our new Premier model is not the first O gauge version of this second-generation pioneer, it offers the best combination of detail, realism, and performance of any 1/48 scale GP35. Added-on detail parts include windshield wipers, metal see-thru body grilles, lift rings, metal grab irons and handrails, see-thru rooftop fan housings, and brake cylinders, air pipes, and swing hangers on our super-detailed Blomberg trucks. And in command mode with the DCS system, you can create a lashup combining one or more GP35s with other Proto-Sound 2.0 first- or second-generation power, and run them from a single throttle just like the prototype.

**NEW!****New York Central** - GP35 Diesel Engine

20-2900-1	Hi-Rail Wheels	\$429.95
20-2900-2	Scale Wheels	\$449.95
20-2900-3	Non-Powered	\$199.95

**NEW!****Gulf Mobile & Ohio** - GP35 Diesel Engine

20-2901-1	Hi-Rail Wheels	\$429.95
20-2901-2	Scale Wheels	\$449.95
20-2901-3	Non-Powered	\$199.95

**POWERED UNITS  
AVAILABLE IN THREE  
ROAD NUMBERS**

**NEW!****Great Northern** - GP35 Diesel Engine

20-2902-1	Hi-Rail Wheels	\$429.95
20-2902-2	Scale Wheels	\$449.95
20-2902-3	Non-Powered	\$199.95

**NEW!****Pennsylvania** - GP35 Diesel Engine

20-2899-1	Hi-Rail Wheels	\$429.95
20-2899-2	Scale Wheels	\$449.95
20-2899-3	Non-Powered	\$199.95

**NEW!****Alaska** - GP35 Diesel Engine

20-2903-1	Hi-Rail Wheels	\$429.95
20-2903-2	Scale Wheels	\$449.95
20-2903-3	Non-Powered	\$199.95



## Features

- Directionally Controlled Headlights
- Intricately Detailed ABS Body
- Metal Wheels, Axles and Gears
- Die-Cast Truck Sides, Pilots and Fuel Tank
- (2) Remotely Controlled Proto-Couplers™
- Colorful Paint Scheme
- Metal Chassis
- (2) Precision Flywheel Equipped Motors
- Locomotive Speed Control In Scale MPH Increments
- Proto-Scale 3-2™ 3-Rail/2-Rail Conversion Capable
- Lighted Cab Interior
- Illuminated Number Boards
- Lighted Marker Lights
- Operating Ditch Lights
- (2) Engineer Cab Figures
- Moveable Roof Fan Blades
- Metal Body Side Grilles
- Operating Smoke Unit
- Proto-Sound® 2.0 With The Digital Command System Featuring: Passenger Station Proto-Effects™
- Unit Measures: 15 1/4 x 2 1/2 x 4 1/16
- Operates On O-31 Curves

Producing 3,000 horsepower and achieving a top speed of 103 mph, F40PHs have regularly traversed this country - perhaps more than any other locomotive. When it was created by EMD in 1976, it was intended for short-haul and commuter trains heated by head-end electricity, but the unit was chosen over the SDP40F, another EMD cowl unit, to head Superliner trains. Once that decision was made, the 500-kw alternator and 1200-gallon fuel tank wasn't adequate. The unit was modified with an 800-kw alternator and an 1800-gallon fuel tank.

The F40PH evolved from the SD-45 and SDO-45 designs. The B-B cowl type locomotive proved remarkably versatile and dependable. Whether heading Amtrak's San Francisco Zephyr and Empire Builder or servicing commuter lines across the nation, the F40PH became an instant railfan favorite.

Pairing the redesigned F40s with complementing passenger cars will add dimension and variety to your modern-era roster. Each engine is outfitted with Proto-Sound 2.0 and contains unique passenger station Proto-Effects only available from M.T.H. Gliding into a station with slow speed precision is possible thanks to the industry-leading Proto-Speed Control system and the unique passenger station sounds make each station stop a truly interactive experience.

### Did You Know?

When F40PHs are in a lash-up, only one unit can supply head-end power for heat and light, the other units supply power for the traction.

**POWERED UNITS  
AVAILABLE IN THREE  
ROAD NUMBERS**



**Canadian American Railroad** - F40PH Diesel Engine

20-2906-1	w/Proto-Sound 2.0	\$429.95
20-2906-3	Non-Powered	\$199.95

### ADD A MATCHING PASSENGER SET!

See Page 158



**VIA Rail** - F40PH Diesel Engine

20-2907-1	w/Proto-Sound 2.0	\$429.95
20-2907-3	Non-Powered	\$199.95



**Amtrak** - F40PH Diesel Engine

20-2905-1	w/Proto-Sound 2.0	\$429.95
20-2905-3	Non-Powered	\$199.95

### ADD A MATCHING PASSENGER SET!

See Page 155

### ADD A MATCHING PASSENGER SET!

See Page 157



**Alaska** - F40PH Diesel Engine

20-2904-1	w/Proto-Sound 2.0	\$429.95
20-2904-3	Non-Powered	\$199.95

# GP-9/GP-7 DIESEL ENGINE



## Features

- Intricately Detailed ABS Body
- Die-Cast Truck Sides, Pilots and Fuel Tank
- Colorful Paint Scheme
- Metal Chassis
- Metal Handrails and Decorative Horn
- (2) Engineer Cab Figures
- Moveable Roof Fan Blades
- Metal Body Side Grilles
- Directionally Controlled Headlights
- Metal Wheels, Axles and Gears
- (2) Remotely Controlled Proto-Couplers™
- (2) Precision Flywheel Equipped Motors
- Locomotive Speed Control In Scale MPH Increments
- Proto-Scale 3-2™ 3-Rail/2-Rail Conversion Capable
- Lighted Cab Interior
- Illuminated Number Boards
- Lighted Marker Lights
- Operating Smoke Unit
- Proto-Sound® 2.0 With The Digital Command System Featuring: Freight Yard Proto-Effects™
- Unit Measures: 14 3/4" x 2 1/2" x 3 3/4"
- Hi-Rail Wheels Operate on O-31 Curves
- Scale Wheels Operate on 18" Radius Curves



Electro-Motive Division's GP (for "General Purpose") engines were the brainchild of project engineer Dick Dilworth. In the late 1940s, Dilworth saw that America's 30,000 miles of main line rail had been virtually dieselized, but the 130,000 miles of secondary lines that carried half of the nation's freight traffic were still largely steam powered. He viewed that as a huge marketing opportunity.

In *The Dilworth Story*, a book published by Electro-Motive Division in 1954, Dilworth explained how he tried to meet that opportunity: "In planning the GP, I had two dreams. The first was to make a locomotive so ugly in appearance that no railroad would want it on the main line or anywhere near headquarters, but would keep it out as far as possible in the back country, where it could do really useful work. My second dream was to make it so simple in construction and so devoid of Christmas-tree ornaments and other whimsy that the price would be materially below our standard main-line freight locomotives."

Of course, Dilworth's explanation conveniently ignored the fact that Alco's arguably uglier RS-1 had introduced the road switcher concept eight years before EMD. And in one sense, Dilworth's project was a failure. Railroads bought Geeps for mainline service and relegated older power to secondary lines as they had always done. But his brainchild became the runaway best-seller among first-generation diesel power. U.S. and Canadian railroads bought nearly 7,000 copies of the 1500 horsepower GP7, introduced in 1949, and the 1750 horsepower GP9, produced from 1954 through 1963.

In those early days of diesel power, experienced engineers loved the Geep cab because, unlike the new streamliners, it felt like home to them. An engineer in a Geep running long hood forward sat near the back of the engine, looking out over the power plant - just as he had in a steam engine. Even running short hood forward, the engineer's view was out past the engine's nose, similar to a steamer.

The GP9 returns to the Premier line in 2008 with the full range of superb detailing you expect in a Premier locomotive: see-through end steps, body side grilles, and roof fan housings; metal side and end handrails; separate metal grab irons; metal lift rings on its roof panels; windshield wipers; and the super-detailed Blomberg trucks introduced earlier on our Premier F-units. Our Geeps also feature authentic first-generation diesel sounds including a single-chime air horn and the throb of an EMD 16-cylinder model 567 prime mover—so named because each of its cylinders displaced 567 cubic inches.

## POWERED UNITS AVAILABLE IN THREE ROAD NUMBERS



**Bangor & Aroostook** - GP-7 Diesel Engine  
20-2895-1 w/Proto-Sound 2.0 \$399.95  
20-2895-3 Non-Powered \$199.95



**Erie** - GP-7 Diesel Engine  
20-2896-1 w/Proto-Sound 2.0 \$399.95  
20-2896-3 Non-Powered \$199.95



**Chesapeake & Ohio** - GP-9 Diesel Engine  
20-2897-1 w/Proto-Sound 2.0 \$399.95  
20-2897-3 Non-Powered \$199.95



**Union Pacific** - GP-9 Diesel Engine  
20-2898-1 w/Proto-Sound 2.0 \$399.95  
20-2898-3 Non-Powered \$199.95

# EMD F3 A-B-A DIESEL ENGINE SET



## Features

- Directionally Controlled Headlights
- Intricately Detailed ABS Bodies
- Metal Wheels, Axles and Gears
- Die-Cast Truck Sides, Pilots and Fuel Tank
- (2) Remotely Controlled Proto-Couplers™
- Colorful Paint Scheme
- Metal Chassis
- Metal Handrails and Decorative Horn
- (2) Precision Flywheel Equipped Motors In Each A Unit
- Locomotive Speed Control In Scale MPH Increments
- Lighted Cab Interiors
- Illuminated Number Boards
- Lighted Front Marker Lights
- Lighted Rear Marker Lights
- (2) Engineer Cab Figures In Each A Unit
- Moveable Roof Fan Blades
- Metal Body Side Grilles
- (2) Operating Smoke Units
- Proto-Scale 3-2™ 3-Rail/2-Rail Conversion Capable
- Proto-Sound® 2.0 With The Digital Command System Featuring: Freight Yard or Passenger Station Proto-Effects™
- Unit Measures: 40 1/4" x 2 5/8" x 3 3/4"
- Operates On O-31 Curves

From 1942-1945, Electro Motive Division's F-unit was the only road freight diesel built in America. While the War Production Board limited competitors Alco and Baldwin to diesel switcher and steam locomotive production during World War II, EMD's 1,350 hp FT became a runaway best-seller. By war's end, Electro Motive had a lead over its competitors that would last until they closed their doors.

With production restrictions lifted and the U.S. economy humming with pent-up demand, railroads clamored for new diesels to replace a steam fleet exhausted by wartime traffic. In July 1946, EMD introduced a new model F-unit, the F3. Horsepower was upgraded to 1,500 and lessons learned on the FT gave the F3 better reliability and lower maintenance. Under the hood throbbed an improved 567-series V-12 engine. With 567 inches of displacement per cylinder, this same engine would power virtually the entire first generation of EMD diesel locomotives.

The F3 hit the market in an era when almost every boy in America wanted toy trains for Christmas, and F3 models quickly became a hot topic in letters to Santa. Such was the desire of railroads for publicity that Lionel® convinced the Santa Fe, the New York Central, and EMD to share the tooling costs for its top-of-the-line F3. Even today, half a century later, the Santa Fe F-unit remains an icon of railroading to the American public.

Capture the excitement of the first-generation diesel era with this full-scale Premier model. With four flywheel-equipped motors, the M.T.H. F3 duplicates the bulldog tenacity of its prototype. Proto-Sound 2.0 offers authentic EMD 567 prime mover sounds, a first-generation diesel horn and bell, crew and station sounds, adjustable smoke volume, and the ability to maintain any speed down to 3 scale miles per hour. Our model features the see-through "chicken wire" screens and rectangular rooftop dynamic brake grilles that characterize most F3s, as well as a host of

added-on details—including legible builder's plates, grab irons, multiple-unit hoses, rooftop lift rings, see-through rooftop fans, steam generator exhaust stack (for passenger car heating), wind-shield wipers, and trucks with separately-applied spring hangers, brake cylinders, and air pipes.

### Did You Know?

In a December 1950 radio show, famed comedian Jack Benny wrote a letter to Dear Santa Fe, saying "Christmas is almost here and it would make me happy if you gave me a train." While the railroad did not give Benny the real train he asked for, its publicity department did send him a toy train model of the F3.



**Spokane Portland & Seattle** - F3 A-B-A Diesel Set  
20-2924-1 w/Proto-Sound 2.0 \$699.95

**Spokane Portland & Seattle** - F3 B-Unit Diesel  
20-2924-3 Non-Powered \$159.95



**Canadian National** - F3 A-B-A Diesel Set  
20-2922-1 w/Proto-Sound 2.0 \$699.95

**Canadian National** - F3 B-Unit Diesel  
20-2922-3 Non-Powered \$159.95



**Santa Fe** - F3 A-B-A Diesel Set  
20-2923-1 w/Proto-Sound 2.0 \$699.95

**Santa Fe** - F3 B-Unit Diesel  
20-2923-3 Non-Powered \$159.95

**ADD A MATCHING PASSENGER SET!**

See Page 157



**Boston & Maine** - F3 A-B-A Diesel Set  
20-2921-1 w/Proto-Sound 2.0 \$699.95

**Boston & Maine** - F3 B-Unit Diesel  
20-2921-3 Non-Powered \$159.95

# SD40-2 DIESEL ENGINE



## Features

- Intricately Detailed ABS Body
- Colorful Paint Scheme
- Metal Chassis
- Die-Cast Truck Sides, Pilots and Fuel Tank
- Metal Wheels, Axles and Gears
- (2) Remotely Controlled Proto-Couplers™
- Metal Handrails and Decorative Horn
- (2) Precision Flywheel Equipped Motors
- Locomotive Speed Control In Scale MPH Increments
- Directionally Controlled Headlights
- Lighted Cab Interior
- Illuminated Number Boards
- Lighted Marker Lights
- (2) Engineer Cab Figures
- Moveable Roof Fan Blades
- Metal Body Side Grilles
- Operating Smoke Unit
- Operating Ditch Lights
- Proto-Scale 3-2™ 3-Rail/2-Rail Conversion Capable
- Proto-Sound® 2.0 With The Digital Command System Featuring: Freight Yard Proto-Effects™
- Unit Measures: 17 1/2" x 2 5/8" x 3 7/8"
- Operates On O-42 Curves

Offering better reliability and lower maintenance costs than the higher powered SD-45, EMD's SD40-2 enjoyed a long production run of 3,100 units. The 3,000 horsepower diesel was the primary motive power for many railroads throughout the 1970's and 80's.

One of the most striking features of the EMD workhorse was its long "back porch" or decking that extended in front and behind the locomotive's cab. These porches differentiated the SD40-2 from its earlier cousin, the SD35 and were the result of the SD40-2's requirement for a longer frame, which helped increase the locomotive's tractive effort.

As one of the most popular road engines for EMD, the SD40-2 has been well represented in the O Gauge marketplace in the past. M.T.H.'s Premier Line SD40-2 offers the user more features and value than any other model. Fully equipped with Proto-Sound 2.0, operating smoke, Proto-Speed Control™ and incredible details ensure that this engine operates as well as it looks.

### Did You Know?

Introduced on January 1, 1972, the SD40-2 had become the best-selling 6-axle road switcher in history by December 31, 1978.

**POWERED UNITS  
AVAILABLE IN THREE  
ROAD NUMBERS**



**British Columbia Railway** - SD40-2 Diesel Engine

20-2908-1	w/Proto-Sound 2.0	\$399.95
20-2908-3	Non-Powered	\$199.95



**Union Pacific** - SD40-2 Diesel Engine

20-2911-1	w/Proto-Sound 2.0	\$399.95
20-2911-3	Non-Powered	\$199.95



**Illinois Central** - SD40-2 Diesel Engine

20-2909-1	w/Proto-Sound 2.0	\$399.95
20-2909-3	Non-Powered	\$199.95



**Marquette** - SD40-2 Diesel Engine

20-2910-1	w/Proto-Sound 2.0	\$399.95
20-2910-3	Non-Powered	\$199.95

# EMD E8 A-B-A DIESEL ENGINE SET



## Features

- Directionally Controlled Headlights
- Intricately Detailed ABS Bodies
- Metal Wheels, Axles and Gears
- Die-Cast Truck Sides, Pilots and Fuel Tank
- (2) Remotely Controlled Proto-Couplers™
- Colorful Paint Scheme
- Metal Chassis
- Metal Handrails and Horn
- (2) Precision Flywheel Equipped Motors In Each A Unit
- Locomotive Speed Control In Scale MPH Increments
- Lighted Cab Interiors
- Illuminated Number Boards
- Lighted Marker Lights
- (2) Engineer Cab Figures In Each A Unit
- Moveable Roof Fan Blades
- Metal Body Side Grilles
- (2) Operating Smoke Units
- Proto-Sound® 2.0 With The Digital Command System Featuring: Passenger Station Proto-Effects™
- Unit Measures: 53" x 2 1/2" x 3 1/2"
- Operates On O-31 Curves

## Did You Know?

The 2250 hp E8 was one of a long line of EMD engines, including the BL2 and F3, to use the 567-series prime mover.

In the mid-1930's, as the Electro-Motive Division of General Motors was trying to interest railroads in diesel passenger power, there was a lot of experimentation in exterior design. Looking at EMD's worm-like yellow and brown Union Pacific M-10000 (shown elsewhere in this catalog), its gleaming stainless steel Burlington Zephyr, or the boxy, just-plain-ugly early Santa Fe units, it's apparent that here was a new function looking for its form. The first generation of road diesels found its form in 1937 when the initial E-units, built for the B&O, inaugurated the classic "covered wagon" cab unit design that would last for two decades on both freight and passenger diesels.

The earliest E-units were each virtually custom-made, with less than 20 units produced of models EA through E5. With the E6, EMD settled on a standardized passenger unit and began to produce it in large quantities, until the war effort arrested production of all passenger diesels in

1942. The E6 was the last passenger diesel to sport the rakish, streamlined EMD nose so characteristic of the 1930s. When the war ended, EMD resumed production of the E-Series with the E7, which featured the "bulldog" nose introduced earlier on the model FT freight diesel. With the introduction of the E8 in 1949, the E-unit, America's most popular passenger diesel, reached its final visual form — just in time for the last hurrah of the American passenger train. With twin motors to ensure reliability and six-wheel trucks that rode like a Cadillac, the E8 was an engineer's dream. For huggers who had not long ago worked in steam locomotives, the clean cab of an E-unit with its lofty, panoramic view of the road ahead was not hard to get used to.

The E8 returns to the Premier line for 2008 in several glorious paint schemes from the golden age of passenger travel. ProtoSound 2.0 brings you the authentic sounds of

the E8's EMD prime movers and the ability to start your train so gently you won't spill the water in the diner — and then accelerate up to scale speeds of over 100 mph, just like the prototype. Our Pennsy version models the E8 set restored by Bennett Levin, CEO of the Juniata Terminal Company, and is offered in semi-gloss paint as these engines are seen today. Whether you model the Pennsy in its heyday or 2008, these engines would be prototypical on your layout. Our Burlington version replicates the units that pulled the California Zephyr, and the Lackawanna E8s headed that road's Phoebe Snow. See the Premier passenger section of this catalog for matching consists for all of these E8s — and for more information on the name trains they pulled, search on the item number for any of these engines on [www.mthtrains.com](http://www.mthtrains.com).



**Pennsylvania** - E8 A-B-A Diesel Set  
20-2894-1 w/Proto-Sound 2.0 \$699.95

**Pennsylvania** - E8 B-Unit Diesel  
20-2894-3 Non-Powered \$159.95

**ADD MATCHING  
PASSENGER SETS!**

See Pages 157-159



**Burlington** - E8 A-B-A Diesel Set  
20-2892-1 w/Proto-Sound 2.0 \$699.95

**Burlington** - E8 B-Unit Diesel  
20-2892-3 Non-Powered \$159.95



**Baltimore & Ohio** - E8 A-B-A Diesel Set  
20-2891-1 w/Proto-Sound 2.0 \$699.95

**Baltimore & Ohio** - E8 B-Unit Diesel  
20-2891-3 Non-Powered \$159.95



**Lackawanna** - E8 A-B-A Diesel Set  
20-2893-1 w/Proto-Sound 2.0 \$699.95

**Lackawanna** - E8 B-Unit Diesel  
20-2893-3 Non-Powered \$159.95

# M10000 DIESEL PASSENGER SET



## Features

- Two-Motored Diesel Locomotive
- 3-Car Passenger Consist
- Directionally Controlled Headlights
- Intricately Detailed ABS Bodies
- Metal Wheels and Axles
- Die-Cast Truck Sides
- Authentic Deco Scheme
- Operates On O-72 Track
- Metal Chassis
- Metal Handrails and Decorative Horn
- (2) Precision Flywheel Equipped Motors
- All Metal Wheels and Gears
- Lighted Marker Lights
- (2) Engineer Cab Figures
- 12 Passenger Figures In Each Car
- Operating Smoke Unit
- Locomotive Speed Control In Scale MPH Increments
- Proto-Sound® 2.0 w/Passenger Station Proto-Effects™
- Complete Set Measures: 52" x 2 1/4" x 3 3/16"



"Tomorrow's Train... TODAY!" heralded a Union Pacific brochure on the M-10000. And indeed it was. The "Little Zip," as UP crews called it, was America's first lightweight, internal-combustion-powered, streamlined train. The UP beat its rival, the Burlington, by rolling out the M-10000 on February 12, 1934 using a 600hp Winton spark-ignition distillate engine, because Winton's diesel was not yet ready. Two months later, Burlington's Zephyr became the first diesel-powered streamliner. That spring and summer, the Little Zip and the Zephyr barnstormed the nation, showing a Depression-weary public that train travel could once again be modern and exciting.

Developed with the aid of a wind tunnel, the M-10000 was lower than a standard passenger train and had a "fishbelly" cross section, with sides that slanted inward toward the roof line (both features are duplicated on our model). It was quiet and fast, with a top speed of over 100 mph.

For safety, the UP painted the train Armour yellow for visibility and installed a skyward-facing beacon just behind the headlight, to warn bystanders of the train's rapid approach. The Little Zip was the first train to wear the bright yellow that soon became a UP trademark.

At first glance, the distinctive look of the M-10000 and the small feet of UP streamliners it spawned in the mid-1930s seems unrelated to later passenger trains. Indeed the M-10000's semi-permanently coupled articulated trainset soon proved impractical, and its monstrous nose air intake, echoed by the 1934 Chrysler Airflow, quickly became yesterday's design. But look closely at the Little Zip's turret cab and rounded nose - reputedly styled by the GM Styling Department under legendary automotive designer Harley Earl - and you'll see the genesis of the EMD E-units and F-units that became the most recognized first-generation diesels. The crew position high

above the rails, protected by the engine's GM-styled nose and offering a panoramic view of the road ahead, was descended not from the shovel-nosed Zephyrs but from the M-10000 and its siblings.

Recreate the summer of 1934, when President Franklin Delano Roosevelt was one of the million visitors who toured the Little Zip, with our replica of the M-10000 in its original glossy paint scheme. This model makes a fitting companion to the Premier Burlington Zephyr cataloged in 2008 Volume One, as the two competing pioneers were sometimes exhibited on adjacent tracks during their whirlwind publicity tours. Or choose the M-10000 in a later paint scheme as it appeared in daily service as the City of Salina. Either way, you'll have an accurate, full-scale model of the pioneering train that prompted one bystander to observe, "They really don't run this Union Pacific Train. They just aim and fire it."



**Union Pacific (Little Zip)** - M10000 Diesel Passenger Set  
20-2925-1 w/Proto-Sound 2.0 \$699.95



**Union Pacific** - M10000 Add-on Passenger Car  
20-2925-3 \$99.95



**Union Pacific (City of Salina)** - M10000 Diesel Passenger Set  
20-2926-1 w/Proto-Sound 2.0 \$699.95



**Union Pacific** - M10000 Add-on Passenger Car  
20-2926-3 \$99.95

To receive the latest updates on catalog items, sign up for our weekly e-newsletter. Go to the News link at the top of our home page,

[www.mthtrains.com](http://www.mthtrains.com)

# AA16 AFB/NOHAB DIESEL ENGINE

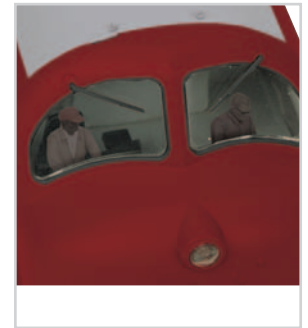

## Features

- Intricately Detailed ABS Body
- Die-Cast Truck Sides, Pilots and Fuel Tank
- Colorful Paint Scheme
- Metal Handrails
- Metal Chassis
- (2) Engineer Cab Figures
- Moveable Roof Fan Blades
- Metal Body Side Grilles
- (2) Precision Flywheel Equipped Motors
- Directionally Controlled Headlights
- Metal Wheels, Axles and Gears
- Supplied With 2 Remotely Controlled Proto-Couplers™ and European Couplers As Well
- Locomotive Speed Control In Scale MPH Increments
- Proto-Scale 3-2™ 3-Rail/2-Rail Conversion Capable
- Lighted Cab Interior
- 1:45 Scale Proportions
- Proto-Sound® 2.0 With The Digital Command System Featuring: Freight Yard Proto-Effects™
- Unit Measures: 16 3/8" x 2 9/16" x 4"
- Hi-Rail Wheels Operate on O-42 Curves
- Scale Wheels Operate on 31" Radius Curves
- Scale-Wheeled engines have fixed pilots
- Hi-Rail Wheeled engines have separate, moveable pilots



**Great Northern - AA16 AFB Diesel**  
 20-2936-1 Hi-Rail Wheels \$449.95  
 20-2936-2 Scale Wheels \$499.95

After conquering the American locomotive market, General Motors took aim at the rest of the world. Looking to Europe for new opportunities, GM inked a deal on April 1, 1950 with NOHAB (Nydqvist & Holm AB), a steam locomotive builder in Trollhättan, Sweden. (If the city sounds familiar, it's because Trollhättan is also home to SAAB, which spun off from NOHAB in the 1930s.) NOHAB-GM locomotives featured a 16-cylinder engine and electrical parts from GM's Electro-Motive Division, and mechanical parts and bodies made by NOHAB. In a trip reminiscent of the pioneering EMD FT diesel's 1939 sales trip over 20 U.S. railroads, NOHAB sent its NOHAB-GM demo unit barnstorming across central Europe in 1955, from Scandinavia to Ankara, Turkey. Because European tonnage needs were smaller than in the United States, and rails were often lighter, the NOHAB diesel was designed as a single, double-ended 1700 hp unit riding on six-axle trucks to spread out the weight. Depending on customer preference, it was available with all six axles powered or with the center axle of each truck as an unpowered idler. Engine power was later upgraded to 1950 hp.

The largest orders received were from Denmark, Norway, and Hungary. On the Danish State Railways (DSB), the NOHAB diesels were designated Class MY and bumped steam from express passenger and heavy freight service. On the Norwegian State Railways, they were Class Di 3, the dominant engine on non-electrified lines. In Hungary they were called Class M61. A less powerful, lighter-weight version, DSB Class MX, was also built for branch line operation. In all cases the NOHAB-GM diesels exceeded customer expectations, proving extremely reliable and long-lived. Manufactured well into the 1960s, they lasted four decades with their original owners, sometimes coming back to work after their planned replacements were not up to the job. Today many of these engines have found a second life after retirement, in areas as diverse as Kosovo and Italy, and with private operators in Denmark, Norway, Germany, and Sweden. One of the more well-known units is on a Swedish railway painted in the Great Northern's 1950s-era green and orange livery. NOHAB diesels also have an avid following among European railfans, and several have been preserved by private owners or state railway museums.

### Did You Know?

A near-identical GM-powered "round-nose" diesel was manufactured by AFB (Anglo-Franco-Belge) in Belgium and worked on the Luxembourg Railways (CFL) and the Belgian Railways (NMBS/SNCB).

### NEW!

**DSB Class MY Denmark** - AA16 NOHAB Diesel  
20-2927-1 Hi-Rail Wheels \$449.95  
20-2927-2 Scale Wheels \$499.95



### NEW!

**NOHAB GM Demo** - AA16 NOHAB Diesel  
20-2928-1 Hi-Rail Wheels \$449.95  
20-2928-2 Scale Wheels \$499.95

### NEW!

**MAV Class M61 Hungary** - AA16 NOHAB Diesel  
20-2929-1 Hi-Rail Wheels \$449.95  
20-2929-2 Scale Wheels \$499.95



### NEW!

**NSB Class Di 3 Norway** - AA16 NOHAB Diesel  
20-2930-1 Hi-Rail Wheels \$449.95  
20-2930-2 Scale Wheels \$499.95

### NEW!

**SNCB Class 202 Belgium** - AA16 NOHAB Diesel  
20-2931-1 Hi-Rail Wheels \$449.95  
20-2931-2 Scale Wheels \$499.95



**NEW! CFL Class 1600 Luxembourg** - AA16 NOHAB Diesel  
20-2932-1 Hi-Rail Wheels \$449.95  
20-2932-2 Scale Wheels \$499.95

### Learn More About It

On the M.T.H. Web site, search on the item number for any of these diesels for links to more information on NOHAB locomotives.

# SD45 DIESEL ENGINE



## Features

- Intricately Detailed ABS Body
- Die-Cast Truck Sides, Pilots and Fuel Tank
- Colorful Paint Scheme
- Metal Chassis
- Metal Handrails and Horn
- (2) Cab Figures
- Moveable Roof Fan Blades
- Metal Body Side Grilles
- Directionally Controlled Headlights
- Metal Wheels, Axles and Gears
- (2) Remotely Controlled Proto-Couplers™
- (2) Precision Flywheel Equipped Motors
- Locomotive Speed Control
- Lighted Cab Interior
- Illuminated Number Boards
- Lighted Marker Lights
- Operating Smoke Unit
- Proto-Scale 3-2™ 3-Rail/2-Rail Conversion Capable
- Proto-Sound® 2.0 With The Digital Command System Featuring: Freight Yard Proto-Effects™
- Unit Measures: 17 1/4" x 3 3/4" x 2 3/4"
- Hi-Rail Wheels Operate on O-42 Curves
- Scale Wheels Operate on 42" Radius Curves

## Did You Know?

Several SD45s have been preserved, including engine 400, the original GN Hustle Muscle. Repainted in its original Omaha Orange and Pullman Green, it resides today in working condition at the Minnesota Transportation Museum in St. Paul.

Like the Pontiac GTO, the SD45 was a mid-60s General Motors muscle car. Stuffed under its brick-like hood was the largest diesel motor made up to that time, a turbo-charged, 20-cylinder, 3600 hp, Electro-Motive Division model 645E. The Great Northern took delivery of the first SD45 in May of 1966 and promptly painted the nickname "Hustle Muscle" on its flanks. The name said it all: the SD45 was heavy freight power, intended for long trains and high speeds. And it had the muscular looks to match, with flared radiators capping a long body that filled every inch of its frame — as opposed to its baby brother, the SD40, which had an open "porch" at each end of the engine.

Unfortunately, the 20-cylinder motor turned out to have a major flaw: a tendency to break its own crankshaft. Even so, a large number of Class 1 railroads rostered the engine, with 1,260 units sold between 1966 and 1971. The Santa Fe, Burlington Northern, Pennsy, and Southern Pacific each owned more than 100 of the heavy freighters. Looking at the order quantities, one can see that the SD45 marked the beginning of a large-scale shift toward six-axle freight engines on American railroads. Before the late '60s, adding a third axle to a truck was mainly an expedient to spread out an engine's weight for service on lighter rail, particularly on branch lines. But with the SD45 and its contemporaries, railroads began favoring the six-axle engine as a way to get more power on the rails for heavier mainline trains. Despite the initial crankshaft problems, many SD45s served their original owners for decades, as well as successor railroads like Conrail and the BNSF, and later went on to new lives at smaller, secondary roads.

New for 2008, our Premier model of this heavy hauler offers an outstanding combination of detail, realism, and performance. Added-on detail parts include windshield wipers, lift rings, metal grab irons and handrails, see-thru rooftop fan housings, and walkways with safety tread. Thanks to Proto-Speed Control, this model can dig in and haul long trains at any speed from a crawl to full throttle. And in command mode with the DCS system, you can create a lashup combining one or more SD45s with any other Proto-Sound 2.0 locomotives, and run them all from a single throttle just like the prototype.



**NEW!** Great Northern - SD45 Diesel Engine

20-2913-1	Hi-Rail Wheels	\$429.95
20-2913-2	Scale Wheels	\$449.95



**NEW!** Milwaukee Road - SD45 Diesel Engine

20-2912-1	Hi-Rail Wheels	\$429.95
20-2912-2	Scale Wheels	\$449.95
20-2912-3	Non-Powered	\$199.95



**NEW!**

**Union Pacific** - SD45 Diesel Engine

20-2915-1	Hi-Rail Wheels	\$429.95
20-2915-2	Scale Wheels	\$449.95
20-2915-3	Non-Powered	\$199.95

**NEW!**

**Santa Fe** - SD45 Diesel Engine

20-2914-1	Hi-Rail Wheels	\$429.95
20-2914-2	Scale Wheels	\$449.95
20-2914-3	Non-Powered	\$199.95



**NEW!**

**Great Northern** - SD45 Diesel Engine

20-2935-1	Hi-Rail Wheels	\$429.95
20-2935-2	Scale Wheels	\$449.95
20-2935-3	Non-Powered	\$199.95

# P5A BOX CAB ELECTRIC ENGINE



## Features

- Directionally Controlled Headlights
- Intricately Detailed Die-Cast Body
- Metal Wheels, Axles and Gears
- Remotely Controlled Operating Pantographs
- Enhanced Detail Die-Cast Truck Sides & Pilots
- (2) Remotely Controlled Proto-Couplers™
- Authentic Paint Scheme
- Metal Chassis
- (2) Precision Flywheel Equipped Motors
- Lighted Cab Interior
- See-Through Metal Body Side Grills
- Opening Doors
- Opening Hatches
- Illuminated Number Boards
- Locomotive Speed Control In Scale MPH Increments
- (2) Engineer Cab Figures
- Proto-Sound® 2.0 With The Digital Command System Featuring: Passenger Station or Freight Yard Proto-Effects™
- Unit Measures: 20" x 2 5/8" x 4"
- Operates On O-72 Curves



Conceived in 1931, the Pennsy's P5a was intended to be the last step in the search for a mainline "juice jack" that had begun with the FF1 in 1917. A collaboration between General Electric, Westinghouse, and the Pennsy's electrical staff, the design proved to be a winner. Engine crews liked the P5a's because they were smooth, powerful, and cleaner than the K4s Pacifics they displaced on many runs. Six 625 hp electric motors geared to three axles with 72-inch drivers gave the new engine 3,750 continuous horsepower and a top speed of 90 mph on passenger runs.

But the success of the Pennsy's passenger service proved too much for the P5a, whose limit was about 8–10 cars on high-speed runs. The introduction of the GG1 in 1934 allowed the Pennsy to operate longer passenger trains with a single locomotive, and pushed the P5a into freight service — where it found its true calling. Regearred to a top speed of 70 mph, the P5a fleet became the backbone of electric freight service on the Pennsy for the next several decades.

The P5a's were originally built with box cabs and, like all box cab locomotives, made engine crews a bit nervous about their exposure in an accident. After a grade crossing collision with a truckload of apples proved fatal for the crew, the final 28 P5a's built in 1934 and 1935 were redesigned with a center cab in the image of the GG1 and labeled P5a Modifieds. In freight service, P5a's were frequently double- and triple-headed; when available, a P5a Modified was used as the lead unit for crew safety.

The P5a Boxcab joins the Premier Line in 2008, a perfect companion for our previously-released P5a Modified. This model is equally at home hustling passenger varnish or dragging a long freight — and thanks to Proto-Sound 2.0, you can easily double- or triple-head boxcab and modified versions just like the prototype.



**Pennsylvania-** P5a Box Cab Electric Engine  
20-5620-1 w/Proto-Sound 2.0 \$799.95



**Pennsylvania-** P5a Box Cab Electric Engine  
20-5619-1 w/Proto-Sound 2.0 \$799.95

### AUTOMATIC PANTOGRAPH OPERATION



**Pennsylvania-** P5a Box Cab Electric Engine  
20-5621-1 w/Proto-Sound 2.0 \$799.95



**Pennsylvania-** P5a Box Cab Electric Engine  
20-5618-1 w/Proto-Sound 2.0 \$799.95

### Did You Know?

The prototype P5a, like our model, featured a blind (unflanged) center axle to allow it to negotiate tighter curves.

**Pennsylvania-** P5a Box Cab Beer Train Set  
20-5636-1 w/Proto-Sound 2.0 \$899.95



# AEM-7 ELECTRIC ENGINE



## Features

- Directionally Controlled Headlights
- Metal Wheels, Axles and Gears
- Die-Cast Truck Sides, Pilots and Fuel Tank
- (2) Remotely Controlled Proto-Couplers™
- Colorful Paint Scheme
- Metal Chassis
- Illuminated Number Boards
- Lighted Marker Lights
- Metal Body Side Grilles
- Intricately Detailed ABS Body
- Lighted Cab Interiors
- Mechanically Operating Pantographs™
- (2) Precision Flywheel Equipped Motors
- (2) Cab Figures
- Overhead Blinking Light
- 1:48 Scale Proportions
- Locomotive Speed Control In Scale MPH Increments
- Proto-Sound® 2.0 With The Digital Command System Featuring: Passenger Station Proto-Effects™
- Unit Measures: 13 1/2" x 2 3/8" x 3 5/8"
- Operates On O-42 Curves



With the demise of the Pennsylvania Railroad in 1968 and the near-death of American passenger trains around the same time, the market for electric engines dried up. Designing new electric locomotives became a lost art in the United States. Not so in Europe, however, where overhead wires were the dominant source of motive power, and virtually every country had a thriving national passenger carrier. It was no wonder, then, that Amtrak turned to Europe in 1977 for a replacement for its aging fleet of ex-Pennsy GG1 locomotives — after an earlier effort, the General Electric E60, had been a bust.

In a contest reminiscent of the 1934 competition between General Electric and Baldwin-Westinghouse designs that spawned the GG1, Amtrak imported a Swedish and a French electric to vie for the title of the G's successor. The four-axle Swedish design proved more suited to American track than its 6-axle French rival, and Amtrak placed an initial order for 30 locomotives. Trucks and electrical gear were made in Sweden by ASEA (Allmänna Svenska Elektriska Aktiebolaget), bodies came from the Budd Company, and American diesel-builder EMD did the final assembly. Officially named the AEM-7 ("A" for ASEA, "EM" for EMD, and "7" for 7,000 horsepower), the engines were soon affectionately dubbed "toasters" for their boxy silver appearance or "Swedish Meatballs." Flying Toasters might have been more appropriate; with nearly half again as much power as a GG1, they can do 125 mph and were the fastest thing on American rails until the Acela arrived. For more than two decades, the Toasters have been the backbone of service on the Northeast Corridor, and today nearly all of them are still in service alongside more modern HHP-8 engines and Acela trainsets.

The AEM-7 returns to the Premier line for 2008, complete with twin motors that give it the same extraordinary power as its prototype. For 2008, we offer the Toaster in its original Amtrak paint scheme and decorated for Maryland's MARC and Pennsylvania's SEPTA — regional roads that also roster AEM-7s. Amtrak AEM-7s have occasionally doubleheaded with MARC and SEPTA units, and NJ Transit has sometimes borrowed SEPTA units, so there is certainly a prototype for modelers who like to mix paint schemes. Also offered for the first time is the AEM-7 in the newest Acela paint scheme. Like the nation's freight railroads, Amtrak has recognized that AC traction motors offer better performance and starting tractive effort than older DC motors, and more than half of the AEM-7 fleet has been upgraded to AC motors in a recent rebuilding program.



**Amtrak** - AEM-7 Electric Engine  
 20-5623-1 w/Proto-Sound 2.0 \$429.95  
 20-5623-3 Non-Powered \$199.95



**ADD MATCHING PASSENGER SETS!**

See Pages 155

**Amtrak** - AEM-7 Electric Engine  
 20-5622-1 w/Proto-Sound 2.0 \$429.95  
 20-5622-3 Non-Powered \$199.95



**Amtrak** - AEM-7 Electric Engine  
 20-5624-1 w/Proto-Sound 2.0 \$429.95  
 20-5624-3 Non-Powered \$199.95

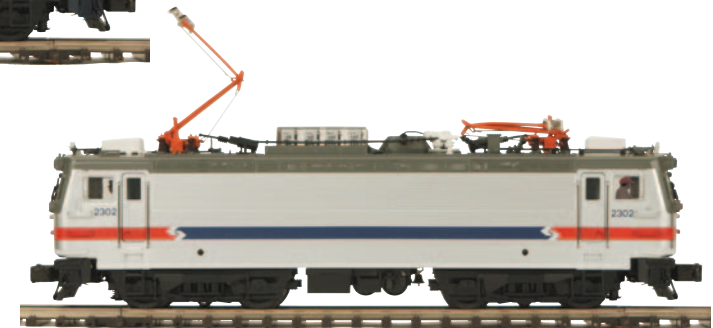

**Septa** - AEM-7 Electric Engine  
 20-5627-1 w/Proto-Sound 2.0 \$429.95  
 20-5627-3 Non-Powered \$199.95



**MARC** - AEM-7 Electric Engine  
 20-5625-1 w/Proto-Sound 2.0 \$429.95  
 20-5625-3 Non-Powered \$199.95

# TRAXX/ALP-46 ELECTRIC ENGINE

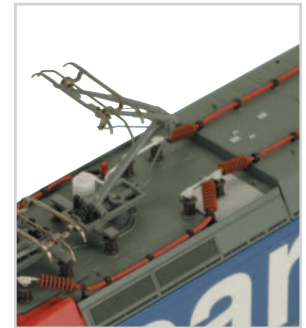

## Features

- 1:45 Scale Proportions
- Directionally Controlled Headlights
- Intricately Detailed ABS Body
- Metal Wheels, Axles and Gears
- Die-Cast Truck Sides, Pilots and Fuel Tank
- Supplied With 2 Remotely Controlled Proto-Couplers™ and European Couplers As Well
- Colorful Paint Scheme
- Metal Chassis
- Metal Handrails and Horn
- (2) Precision Flywheel Equipped Motors
- Locomotive Speed Control In Scale MPH Increments
- Proto-Scale 3-2™ 3-Rail/2-Rail Conversion Capable
- Lighted Cab Interior
- (2) Engineer Cab Figures
- Metal Body Side Grilles
- Proto-Sound® 2.0 With The Digital Command
- System Featuring: Passenger Station or Freight Yard Proto-Effects™
- Unit Measures: 18" x 2 11/16" x 4"
- Hi-Rail Wheels Operate on O-42 Curves
- Scale Wheels Operate on 42" Radius Curves

Since the dawn of the Orient Express in 1883, Europeans have dreamed of a rail network that would transcend national borders. For more than a century, the best that could be accomplished was the handoff of passenger or freight consists from one national rail system to another, usually stopping at the border to change motive power. Even when most of the continent went to overhead wires to supply motive power, voltage and current were often different from one country to another. Today, however, all that is changing. Sporting service names like "EuroCity" and slogans like "Connecting Europe," electric engines glide seamlessly and swiftly across borders, and carriers offer freight and passenger services that span many nations.

With locomotive and car manufacturing facilities on four continents, Bombardier has emerged as a leader in the manufacture of equipment for these multinational rail carriers. Starting with electric locomotive technology developed by German firm Adtranz, which Bombardier acquired in 2001, Bombardier developed the TRAXX family of electric and diesel locomotives for service across Europe. TRAXX electrics feature modular construction and can be configured to run on multiple voltages and both AC and DC. Leading purchasers have included freight carriers with multinational networks, including Cargo, the freight division of the Swiss Federal Railways that runs through Germany, Switzerland, and Italy, and Railion, which spans Denmark, the Netherlands, Germany, Switzerland, and Italy.

The TRAXX electric offers a near-perfect combination of speed, safety, and practicality. Its streamlined shape is designed for aerodynamics but also for economical construction, being composed almost entirely of flat surfaces. The ends are raked at an angle that slices through the air — but a steeper, more streamlined angle was avoided in order to minimize air turbulence between the engine and the following car. The controls, of course, are fully computerized with myriad safety systems. With up to 800 horsepower being delivered to each of its eight wheels, wheelslip control on the TRAXX was mandatory. Another system automatically ensures adherence to speed restrictions and trackside signals.

But the most practical feature of the TRAXX electric has nothing to do with speed or safety. It turns out the engine's smooth, flat sides make a perfect rolling billboard, either for publicizing the owner or selling ad space for additional revenue. The most complex images can be printed on a heavy plastic foil and applied neatly to the engine, and changed easily when necessary. Passenger engines based on the same platform have carried graphics publicizing rock musicals, vacation destinations, and even UNICEF.



**NEW! SBB Cargo Switzerland** - TRAXX F140 AC Electric Engine

20-5632-1	Hi-Rail Wheels	\$449.95
20-5632-2	Scale Wheels	\$499.95
20-5632-3	Non-Powered	\$219.95



**NEW! Veolia Transport Germany** - TRAXX P160 AC2 Electric Engine

20-5633-1	Hi-Rail Wheels	\$449.95
20-5633-2	Scale Wheels	\$499.95



**NEW! Railion European** - TRAXX F140 AC2 Electric Engine

20-5634-1	Hi-Rail Wheels	\$449.95
20-5634-2	Scale Wheels	\$499.95
20-5634-3	Non-Powered	\$219.95



**NEW! DEMO** - TRAXX F140 AC2 Electric Engine

20-2937-1	Hi-Rail Wheels	\$449.95
20-2937-2	Scale Wheels	\$499.95

# EP-3 ELECTRIC ENGINE



## Features

- Directionally Controlled Headlights
- Intricately Detailed Die-Cast Body
- Metal Wheels, Axles and Gears
- Remotely Operated Pantographs
- Die-Cast Truck Sides & Pilots
- (2) Remotely Controlled Proto-Couplers™
- Authentic Paint Scheme
- Metal Chassis
- Metal Handrails
- (2) Precision Flywheel Equipped Motors
- Locomotive Speed Control In Scale MPH Increments
- Lighted Cab Interior
- Illuminated Number Boards
- Lighted Marker Lights
- (2) Cab Figures
- Proto-Sound® 2.0 With The Digital Command System Featuring: Passenger Station Effects™
- Unit Measures: 20 3/4" x 4" x 2 3/4"
- Operates On O-72 Curves



Although the Pennsylvania took pride in calling itself "The Standard Railroad of the World," its most famous locomotive had its roots in a General Electric-designed product borrowed from its much smaller neighbor to the north. The New York, New Haven & Hartford's ten rather plain-looking EP-3 electrics were the fathers of the Pennsy's legendary fleet of 139 GG1s.

Built in 1931, the EP-3 was General Electric's effort to steal the New Haven's business away from rival Westinghouse Electric - and it worked. The EP-3 could easily hurry 15 heavyweight Pullmans down the road at 70mph, and its success led the New Haven to purchase almost all future electric locomotives from GE. Bigger than any previous New Haven juice jacks, the EP-3 was, in electric locomotive parlance, a 2-C+C-2: a two-axle, unpowered guide truck at each end and a pair of three-axle powered trucks in the middle. Each driven axle was powered by two electric motors. The last box cab electrics built for the New Haven, the EP-3s were nicknamed "flat bottoms" by their crews.

While the EP-3's were thriving on the New Haven in the early 1930s, things were not going as well with the Pennsy's new electrification project. The P-5 electrics intended to be the road's signature passenger engines turned out to be short on power and possessed of tracking problems. The Pennsy borrowed several EP-3s for testing, built its own experimental prototype based on those engines, and, as they say, the rest is history. It is no coincidence that, below the body, a Pennsylvania GG1 and a New Haven EP-3 look very much the same. While the EP-3s did not last as long as the GG1s, they did have an extraordinarily long career, with the last EP-3 being retired in 1961.

The EP-3 returns to the M.T.H. Premier lineup fully outfitted with Proto-Sound 2.0. Featuring a die-cast body and chassis, the EP-3 also includes automatic operating pantographs. Watch as each pantograph extends or retracts when the locomotive changes direction. The pantographs are also fully controllable in command mode when using the DCS system.

**See the luxuries awaiting you on *The East Wind!***

For info on the East Wind, search on the item number for this set on our Web site.



**New Haven** - EP-3 Electric Engine  
20-5629-1 w/Proto-Sound 2.0 \$799.95

**DIE-CAST  
METAL BODY**



**NY, NH & Hartford** - EP-3 Electric Engine  
20-5630-1 w/Proto-Sound 2.0 \$799.95

**REMOTELY  
OPERATED  
PANTOGRAPHS**



**New Haven** - EP-3 Electric Engine  
20-5628-1 w/Proto-Sound 2.0 \$799.95

**New Haven - The East Wind** - EP-3 Passenger Set  
20-5631-1 w/Proto-Sound 2.0 \$899.95



# FF-1/EP-2 ELECTRIC ENGINE



## Features

- Directionally Controlled Headlights
- Intricately Detailed Die-Cast Body
- Metal Wheels, Axles and Gears
- Remotely Controlled Operating Pantographs\*
- Enhanced Detail Die-Cast Truck Sides & Pilots
- (2) Remotely Controlled Proto-Couplers™
- Authentic Paint Scheme
- Metal Chassis
- (2) Precision Flywheel Equipped Motors
- Lighted Cab Interior
- See-Through Metal Body Side Grills
- Opening Doors
- Opening Hatches
- Illuminated Number Boards
- Lighted Marker Lights
- Locomotive Speed Control In Scale MPH Increments
- (2) Engineer Cab Figures
- Proto-Sound® 2.0 With The Digital Command System Featuring: Freight Yard or Passenger Station Proto-Effects™
- FF-1 Measures: 19 1/8" x 2 1/2" x 3 7/8"
- FF-1 Operates On O-72 Curves
- EP-2 Measures: 20 x 2 1/2 x 4 5/8
- EP-2 Operates On O-72 Curves

\*Not featured on EP-2 Models

## Did You Know?

Big Liz was capable of 4000 continuous horsepower at the rail and a maximum of 4800 hp when starting a heavy train. Like most electrics, her starting effort was greater because her electric motors could handle a large overload for a brief period of time.

Check 'em out at your dealer's now! Our superbly detailed, smooth-running models of these historic electric locomotives are currently in stock at M.T.H.

## Pennsylvania FF1

Built by the road's Juniata shops in 1917, the FF1 was the first step in the Pennsy's long search for a heavy-duty mainline electric locomotive - a search that would culminate in 1934 with the GG1, perhaps the most successful and best-loved electric ever built. The FF1, however - like her contemporary, the Erie Triplex 2-8-8-2 shown elsewhere in this catalog - was a monstrous machine that was simply too big and too powerful for the technology of her time. Like the Triplex, she became known for ripping the couplers out of freight cars and was soon relegated to pusher service, where the railroad figured she would do less damage.

The first-ever O gauge model of this historic locomotive, our Premier FF1 recreates the visual and mechanical excess of the original design, but runs better than the prototype ever did. Only MTH engineering could make such a large, complex model run smoothly and steadily at speeds from a barely perceptible crawl to wide-open throttle. For a perfect World War I era freight train, team Big Liz up with the Pennsy N6b caboose shown elsewhere in this catalog and our USRA single- and double-sheathed wooden boxcars from earlier catalogs.

## Premier Milwaukee Road EP-2 Bi-Polar

Chicago Milwaukee, St. Paul, and Pacific. The Milwaukee Road's full name described its route perfectly - from the Midwest to the Northwest with not much in between. In 1919, this sparsely traveled mountainous route seemed the ideal place for the General Electric Company and the railroad to prove a point: electric power was the Future of American Railroading. And the five EP-2 Bi-Polars were going to be the engines to do it.

Officially called Bi-Polar Gearless Types, they were vastly superior to the steam locomotives of their day. With 3,200 continuous horsepower, an EP-2 could pull 13 Pullmans up a 2.2% grade, an incredibly steep hill in real-life railroading. When the Bi-Polars were young, their owners and builders delighted in staging pulling contests such as a 1924 "Battle of the Giants," in which a Bi-Polar easily won a tug-of-war against a pair of steam locomotives, a 2-8-0 and a 2-6-6-2.

Recreate the Olympian of the 1920s with the Bi-Polar in its as-delivered black paint scheme, or the postwar Olympian Hiawatha. Either way, you'll get to watch one of the smoothest-running electrics in O gauge snake its way through curves, blow smoke from its train heat boiler, and start and stop so gently that you'll never spill the water in the diner.

For more information on either of these locomotives, search on its item number on [www.mthtrains.com](http://www.mthtrains.com).



### REMOTELY OPERATED PANTOGRAPHS

**Pennsylvania** - FF-1 Electric Engine  
20-5588-1 w/Proto-Sound 2.0 \$799.95



**Pennsylvania** - FF-1 Electric Engine  
20-5589-1 w/Proto-Sound 2.0 \$799.95



**Milwaukee Road** - Ep-2 Bipolar Electric  
20-5608-1 w/Proto-Sound 2.0 \$699.95



**Milwaukee Road** - Ep-2 Bipolar Electric  
20-5606-1 w/Proto-Sound 2.0 \$699.95

# R40/BMT 2500 SUBWAY SETS



## Features

- Directionally Controlled Headlights
- Intricately Detailed ABS Bodies
- Metal Wheels and Axles
- Detailed Car Interiors
- Locomotive Speed Control In Scale MPH Increments
- Die-Cast Truck Sides
- (1) Remotely Controlled Proto-Couplers
- Authentic Paint Scheme
- Operates on O-42 Curves
- All Metal Wheels and Gears
- Illuminated Destination Boards
- (2) Precision Flywheel Equipped Motors In Power Unit
- Metal Chassis
- 10 Passenger Figures In Each Non-Powered Car
- Lighted Car Interiors
- Proto-Sound® 2.0 With the Digital Command System Featuring Passenger Station Stop Proto-Effects™
- BMT 3-Car Set Measures: 52" x 2 1/2" x 3"
- BMT Operates On O-42 Curves
- R40 4-Car Set Measures: 64 1/2" x 2 1/4" x 3 1/4"
- R40 Operates On O-42 Curves



From Brooklyn in the 1920s to Manhattan today, M.T.H. subway models recreate the history of New York's vast transit system. Our beautifully detailed models of two landmark New York cars are at your dealer's now.

The BMT 2500-series cars, often called BMT Standards, served Brooklyn for 50 years. At the time of their construction in the World War I era, they represented the state of the art in transit cars. Their spacious interiors were 16' longer and a foot wider than those of competitive IRT cars. But fifty years later, as the BMT Standards rode

out their final years, passengers must have felt they were stepping into a time warp when they rode these non-air conditioned cars with wooden window sashes lit by bare incandescent light bulbs.

The R40 was one of famed industrial designer Raymond Loewy's few flops. To give the new stainless steel cars an exciting look, Loewy's firm designed a molded fiberglass end cap with a 15-degree slant. Apparently no one thought to test the design before it went into production, and the new cars entered service on March 23, 1968. By

early April, it became apparent that the slant ends presented a great danger to passengers walking from car to car, because they had to cross a large gap with nothing to hold onto. Within months, the cars were retrofitted with elaborate pantograph gates on the slant ends, which effectively destroyed Loewy's rakish design but allowed passengers to wander from car to car in safety.

For more information on either of these models, search on its item number on [www.mthtrains.com](http://www.mthtrains.com).



**Metropolitan Transportation** - BMT 2500 Series 3-Car Subway Set  
20-2675-1 w/Proto-Sound 2.0 \$449.95



**Metropolitan Transportation** - BMT 2500 Series 3-Car Subway Set Add-On  
20-2675-3 Non-Powered \$299.95



**Metropolitan Transportation** - R40 2-Car Subway Set Add-On  
20-2717-3 Non-Powered \$199.95



**Metropolitan Transportation** - R40 4-Car Subway Set  
20-2717-1 w/Proto-Sound 2.0 \$499.95



# R-11 4-CAR SUBWAY SET

## Features

- Directionally Controlled Headlights
- Intricately Detailed ABS Bodies
- Metal Wheels and Axles
- Detailed Car Interiors
- Locomotive Speed Control In Scale MPH Increments
- Die-Cast Truck Sides
- (1) Remotely Controlled Proto-Coupler™
- Authentic Paint Scheme
- Operates on 0-42 Curves
- All Metal Wheels and Gears
- Illuminated Destination Boards
- (2) Precision Flywheel Equipped Motors In Power Unit
- Metal Chassis
- Fast-Angle Wheel Sets
- Overhead Interior Lighting
- Lighted Interior
- Proto-Sound® 2.0 With the Digital Command System Featuring Passenger Station Stop Proto-Effects™
- 2-Car Set Measures: 32 1/4" x 2 1/2" x 3 3/8"
- 4-Car Set Measures: 63 1/2" x 2 1/2" x 3 3/8"



Like the Union Pacific M-10000 featured elsewhere in this catalog, the R-11 was billed - accurately - as the Train of the Future: "Expectations are high for construction of the Second Avenue subway and the futuristic new subway cars that will run on it. Made from gleaming stainless steel, the cars have a range of modern innovations: round porthole windows that would look at home on a rocket ship; high-tech air purification systems that use ultraviolet lamps to kill germs; illuminated route maps on the wall; and - incredible as it seems - public address systems that make clear, intelligible announcements."

In 1949 the New York Board of Transportation, predecessor of today's Metropolitan Transportation Authority, took delivery of ten R-11 subway cars from the Budd Company, the prototypes of a 400-car fleet to run on the planned Second Avenue subway. Having recently convinced the nation's railroads that stainless steel streamliners were the cars of the future, Budd saw the R-11 as an opportunity to make a similar conquest in the subway

business. Styled by industrial designer Otto Kuhler, the bright and shiny R-11, with its equally large windows for seated passengers and standees, stood in stark contrast to the darkly painted, dingy cars of the era. In part because polio was a concern at the time, the R-11 was equipped with a ventilation system that brought in outside air and ran it past "precipitron" sterilizing lamps (ultraviolet lamps) to kill germs. The inviting interiors featured faux wicker plastic upholstery and another modern innovation, fluorescent lighting.

Unfortunately, construction didn't start on the Second Avenue subway for another 58 years, and the ten prototype R-11s were the only ones ever built. Unable to mate with any of New York's other car types, the R-11s wandered the system from one assignment to another, including the Canarsie line and the Franklin Avenue shuttle. It would be another 15 years before New York would order another stainless steel car, the R-32, also from Budd. In a 1965 rebuild, the R-11's saw their warm interiors replaced

with hard fiberglass seats, but gained the ability to operate with other cars, and in 1977 they were retired. One survives today in the New York Transit Museum.

New for 2008, the Premier R-11 accurately recreates the futuristic look of the original, complete with shiny plated exterior. The R-11 also features transit stop simulation available only from M.T.H. Designed specifically for our municipal transit cars, the unique Proto-Sound 2.0 transit program features Station Stop Proto-Effects, allowing you to program the train to stop automatically at designated station stops, even in Conventional Mode. When configured to run on automatic, the R-11 stops itself at locations you define and calls out station names that you select in advance; the train essentially runs itself. And when you program the R-11 for an out-and-back route, it even reverses itself and heads back downtown when it reaches the end of the line - stopping along the way at each station to broadcast the name of the stop and the hustle and bustle of passengers coming and going.



**NEW!** Metropolitan Transportation- R-11 4-Car Subway Set  
20-2934-1 w/Proto-Sound 2.0 \$499.95



**NEW!** Metropolitan Transportation- R-11 2-Car Subway Set Add-On  
20-2934-3 Non-Powered \$199.95



**NEW!** Metropolitan Transportation- R-11 4-Car Subway Set  
20-2933-1 w/Proto-Sound 2.0 \$499.95



**NEW!** Metropolitan Transportation- R-11 2-Car Subway Set Add-On  
20-2933-3 Non-Powered \$199.95

### Learn More About It

Learn more about it: For more information on the R-11 and the entire New York City transit system, visit [www.nycsubway.org](http://www.nycsubway.org).

### PLATED EXTERIOR FINISH!

# Premier Freight: CHECK OUT THE DETAILS

If you haven't handled a Premier freight car in awhile, take another look. Throughout the Premier freight line, we've ramped up the realism with additional detailing and more added-on parts. The Center Beam Flat Car shown here, for example, features separate metal ladder rungs and a separate brake chain. Remove the colorfully wrapped lumber loads and you'll find prototypical safety warnings to prevent your forklift operator from loading the car unevenly and causing it to tip over. And under all M.T.H. freight cars you'll find the smoothest-rolling trucks in O gauge, complete with hidden uncoupling plates, not old-fashioned thumbtacks.

For additional detail photos of any Premier freight car, search on its item number on the M.T.H. home page, [www.mthtrains.com](http://www.mthtrains.com)



# N-6b Caboose w/Operating Signal Man



**New Haven** - N-6b Caboose w/Operating Signal Man  
20-91280 \$89.95



**Pennsylvania** - N-6b Caboose w/Operating Signal Man  
20-91281 \$89.95

## Details

- Intricately Detailed Durable ABS Body
- Metal Wheels and Axles
- Caboose Interiors With Overhead Lighting
- Die-Cast 4-Wheel Trucks
- Operating Die-Cast Metal Couplers
- Colorful, Attractive Paint Schemes
- Decorative Brake Wheels
- Brakeman Figure
- Separate Metal Handrails
- Fast-Angle Wheel Sets
- Needle-Point Axles
- 1:48 Scale Dimensions
- Moving Signal Man w/Operating Lantern
- Unit Measures: 9" x 2 7/8" x 4 1/16"
- Operates On O-31 Curves

## Signal Man Leans out with Lighted Lantern



# Operating Reefer Car



**Railway Express Agency** - Operating Reefer Car  
20-94211 \$99.95

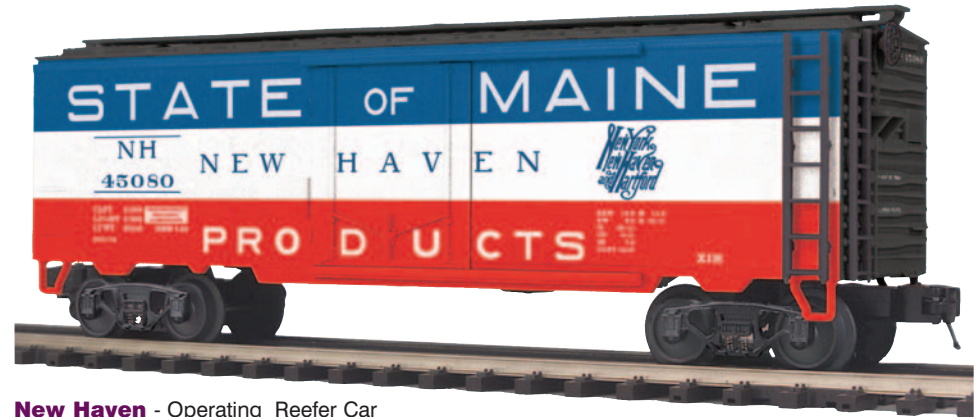

**New Haven** - Operating Reefer Car  
20-94210 \$99.95

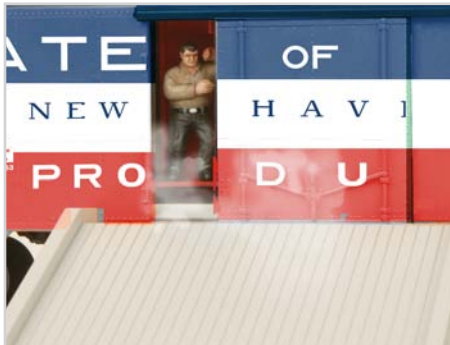

**Door Opens and Frost Escapes**

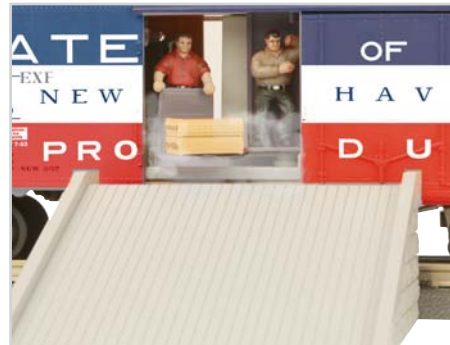

**First Load is pushed out**



## Details

- Metal Wheels and Axles
- Die-Cast 4-Wheel Trucks
- Operating Die-Cast Metal Couplers
- Colorful, Attractive Paint Schemes
- Decorative Brake Wheels
- Fast-Angle Wheel Sets
- Needle-Point Axles
- Operating Interior Lighting

- Intricately Detailed Durable ABS Body
- Auto Opening Door
- Operating Workman Pushes Out Load
- Simulated Dry-Ice "Smoke"
- Unit Measures: 11 5/8" x 2 3/4" x 3 9/16"
- Operates On O-31 Curves

MTH Premier O Scale operating freight cars bring life and excitement to your O Scale layout. Sized to scale, each car is a perfect complement to any manufacturer's scale proportioned O Gauge locomotives.

The car comes to life when parked on an operating track section. When the track section is activated, the car door will slowly slide open evidenced by a rush of foggy cold air. A worker inside carefully slides out the first pallet of refrigerated goods, tirelessly repeating the process until all the pallets are unloaded. The door then closes and the train can move up for the next car.

# 40' AAR BOX CAR



**Chesapeake & Ohio** - 40' AAR Box Car  
20-93419 \$49.95



**Union Pacific** - 40' AAR Box Car  
20-93422 \$49.95



**Great Northern** - 40' AAR Box Car  
20-93420 \$49.95



**Santa Fe** - 40' AAR Box Car  
20-93421 \$49.95

## Details

- O Scale Kadee® Compatible Mounting Pad
- Opening Doors
- Unit Measures: 11 1/2" x 2 5/8" x 3 3/4"
- Operates on O-31 Curves



# 40' Box Car



**Detroit Toledo & Ironton** - 40' Box Car  
20-93428 \$44.95



**Ontario Northland** - 40' Box Car  
20-93429 \$44.95



**Reading** - 40' Box Car  
20-93430 \$44.95



**Boston & Maine** - 40' Box Car  
20-93427 \$44.95

## Details

- O Scale Kadee® Compatible Mounting Pad
- Opening Doors
- Unit Measures: 11 1/2" x 2 5/8" x 3 3/4"
- Operates on O-31 Curves





# 50' Box Car



**Canadian National** - 50' Box Car  
20-93423 \$49.95

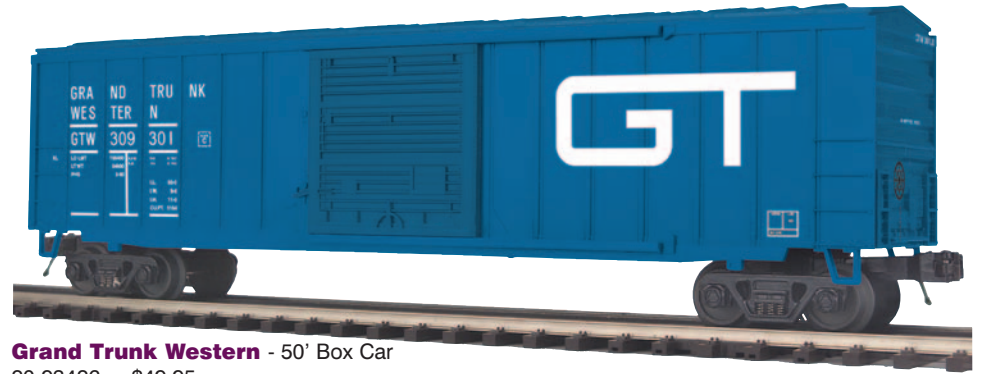

**Grand Trunk Western** - 50' Box Car  
20-93426 \$49.95



**Canadian Pacific** - 50' Box Car  
20-93424 \$49.95



**Conrail** - 50' Box Car  
20-93425 \$49.95

## Details

- O Scale Kadee® Compatible Mounting Pad
- Opening Doors
- Unit Measures: 14 1/2" x 2 5/8" x 4 3/16"
- Operates on O-31 Curves

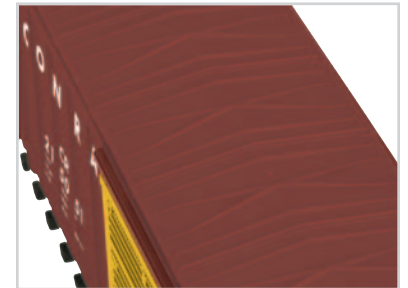

# R50B Express Reefer Car



**New York Central** - R50B Express Reefer Car  
20-94155 \$59.95



**Santa Fe** - R50B Express Reefer Car  
20-94157 \$59.95



**Pennsylvania** - R50B Express Reefer Car  
20-94156 \$59.95



**Milwaukee Road** - R50B Express Reefer Car  
20-94154 \$59.95

## Details

- O Scale Kadee® Compatible Mounting Pad
- Opening Doors
- Unit Measures: 14 1/2" x 2 1/2" x 3 1/2"
- Operates on O-31 Curves

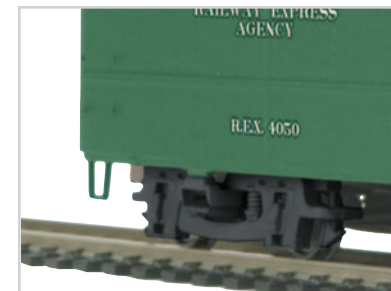

# 36' Woodsided Reefer Car



**Rolling Rock** - 36' Woodsided Reefer Car  
20-94341 \$54.95

"© 2008 Anheuser-Busch, Inc. All Rights Reserved."

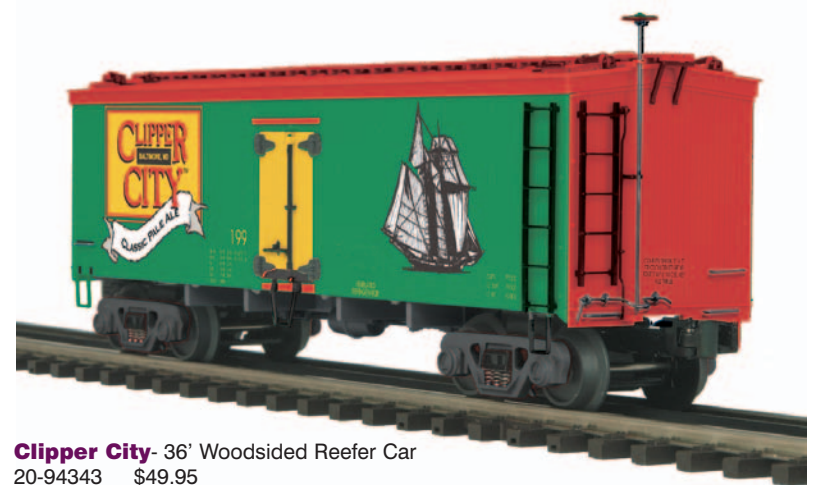

**Clipper City** - 36' Woodsided Reefer Car  
20-94343 \$49.95

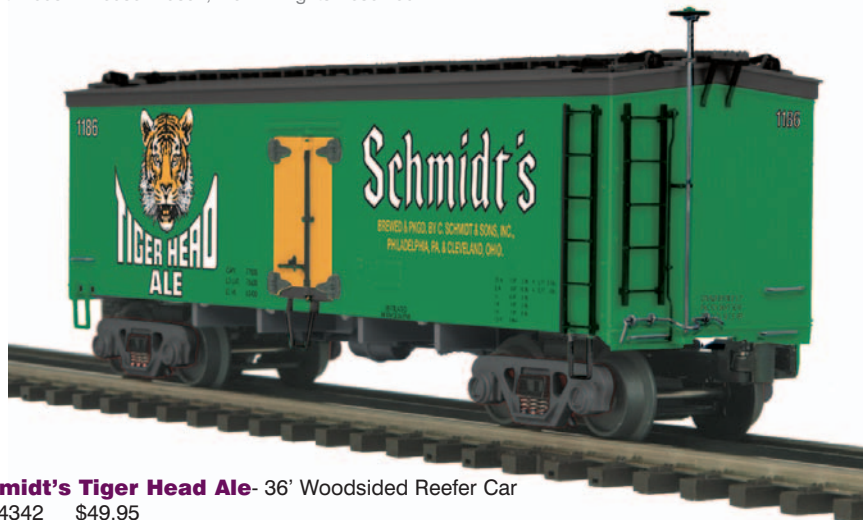

**Schmidt's Tiger Head Ale** - 36' Woodsided Reefer Car  
20-94342 \$49.95

## Details

- O Scale Kadee® Compatible Mounting Pad
- Opening Doors
- Unit Measures: 10 3/4" x 2 3/8" x 3 1/4"
- Operates on O-31 Curves

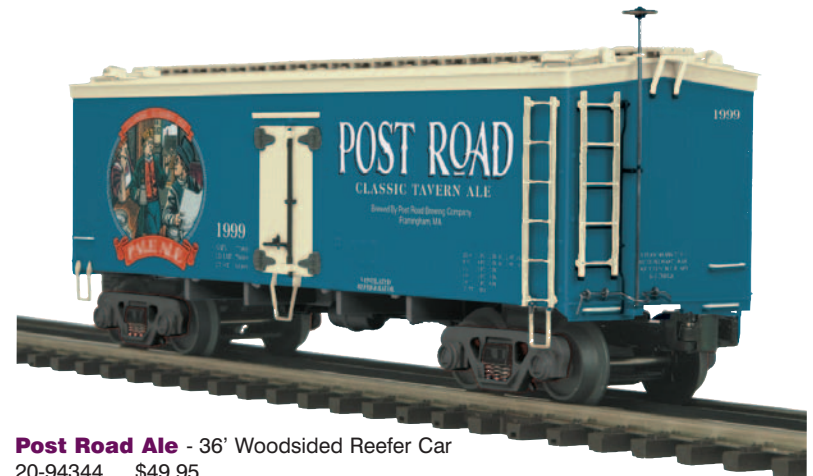

**Post Road Ale** - 36' Woodsided Reefer Car  
20-94344 \$49.95



# 40' Steel Sided Reefer Car



**Boulevard Pale Ale** - 40' Steel Sided Reefer Car  
20-94207 \$49.95



**Dukes Beer** - 40' Steel Sided Reefer Car  
20-94208 \$49.95



**Beverwyck Irish Cream Ale** - 40' Steel Sided Reefer Car  
20-94209 \$49.95



**Peoples Beer** - 40' Steel Sided Reefer Car  
20-94206 \$49.95

## Details

- O Scale Kadee® Compatible Mounting Pad
- Opening Doors
- Unit Measures: 11 3/4" x 2 9/16" x 3 1/2"
- Operates on O-31 Curves



# Coalporter Hopper Car



**Norfolk Southern** - Coalporter Hopper Car  
20-97228 \$54.95



**Union Pacific** - Coalporter Hopper Car  
20-97226 \$54.95

**ROTATING  
COUPLERS**



**CSX** - Coalporter Hopper Car  
20-97227 \$54.95



**Burlington Northern** - Coalporter Hopper Car  
20-97225 \$54.95

## Details

- Rotating Coupler For Rotary Dump Operations
- O Scale Kadee® Compatible Mounting Pad
- Unit Measures: 13 1/8" x 2 5/8" x 3 3/8"
- Operates on O-31 Curves

**ADD A MATCHING  
COALPORTER HOPPER SET!**

See Page 150

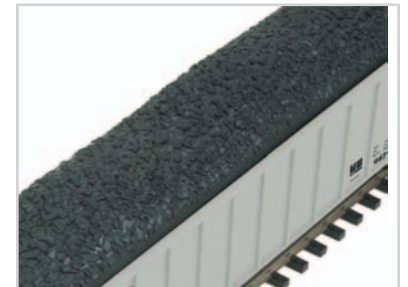

# 3-Bay Centerflow Hopper



**Kansas City Southern**- 3-Bay Centerflow Hopper  
20-97665 \$49.95



**CSX**- 3-Bay Centerflow Hopper  
20-97664 \$49.95

## Details

- O Scale Kadee® Compatible Mounting Pad
- Unit Measures: 13 7/8" x 2 11/16" x 3 7/8"
- Operates on O-31 Curves

**ADD A MATCHING  
CENTERFLOW HOPPER SET!**

See Page 151



**Norfolk Southern**- 3-Bay Centerflow Hopper  
20-97666 \$49.95



**BNSF**- 3-Bay Centerflow Hopper  
20-97663 \$49.95

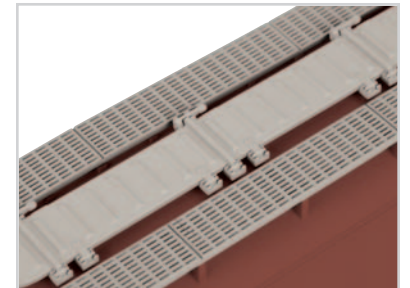

# 2-Bay Offset Hopper Car



**Pittsburgh & West Virginia** - 2-Bay Offset Hopper Car  
20-97661 \$44.95



**Lehigh New England** - 2-Bay Offset Hopper Car  
20-97660 \$44.95



**Reading** - 2-Bay Offset Hopper Car  
20-97662 \$44.95



**Conrail** - 2-Bay Offset Hopper Car  
20-97659 \$44.95

## Details

- O Scale Kadee® Compatible Mounting Pad
- Unit Measures: 9 1/2" x 2 1/2" x 3"
- Operates on O-31 Curves



# 8000 Gallon Tank Car



**Iron City** - 8000 Gallon Tank Car  
20-96178 \$49.95



**Killians Red** - 8000 Gallon Tank Car  
20-96179 \$49.95

## Details

- O Scale Kadee® Compatible Mounting Pad
- Unit Measures: 9 1/16" x 2 3/4" x 3 7/8"
- Operates On O-27 Curves

© 2008 Molson Coors Global Properties, LLC Coors trademarks are properties of Molson Coors Global Properties, LLC, used under license by M.T.H. Electric Trains Limited Edition Adult Collectible-This licensed product is intended for purchase and enjoyment by individuals of legal purchase age for alcohol beverages. The Killian's trademark is owned by Brasseries Pelforth, S.A.



**A&W Root Beer** - 8000 Gallon Tank Car  
20-96180 \$49.95

A&W is a trademark of A&W Concentrate Company, used under license by M.T.H. Electric Trains. ©2008 A&W Concentrate Company



**7UP** - 8000 Gallon Tank Car  
20-96181 \$49.95

7UP is a trademark of Dr Pepper/Seven Up, Inc., used by M.T.H. Electric Trains under license. ©2008 Dr Pepper/Seven up, Inc.





# Tank Car



**BNSF** - Tank Car  
20-96174 \$49.95



**John Deere** - Tank Car  
20-96175 \$54.95

John Deere is a registered trademark of Deere & Company.



**Coors Light** - Tank Car  
20-96177 \$54.95

© 2008 Molson Coors Global Properties, LLC Coors trademarks are properties of Molson Coors Global Properties, LLC, used under license by M.T.H. Electric Trains Limited Edition Adult Collectible-This licensed product is intended for purchase and enjoyment by individuals of legal purchase age for alcohol beverages.



**Caterpillar®** - Tank Car  
20-96176 \$54.95

© 2008 Caterpillar  
CAT, CATERPILLAR, their respective logos, "Caterpillar Yellow" and the POWER EDGE trade dress, as well as corporate and product identity used herein, are trademarks of Caterpillar and may not be used without permission.

## Details

- O Scale Kadee® Compatible Mounting Pad
- Unit Measures: 12" x 2 3/4" x 4 3/16"
- Operates On O-27 Curves

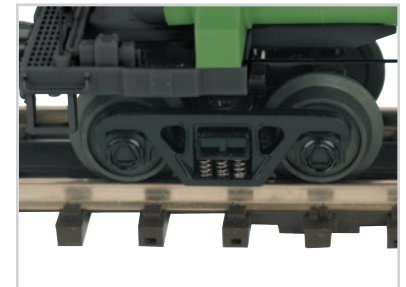

# Gondola Car w/Coiled Wire Load



**Maryland Midland** - Gondola Car w/Coiled Wire Load  
20-98073 \$44.95



**Canadian National** - Gondola Car w/Coiled Wire Load  
20-98072 \$44.95



**New York Central** - Gondola Car w/Coiled Wire Load  
20-98074 \$44.95



**Southern Pacific** - Gondola Car w/Coiled Wire Load  
20-98075 \$44.95

## Details

- O Scale Kadee® Compatible Mounting Pad
- Unit Measures: 14 5/8" x 2 5/8" x 3 15/16"
- Operates on O-31 Curves



# Gondola Car w/Wheel Scrap Load



**Ann Arbor** - Gondola Car w/Wheel Scrap Load  
20-98076 \$44.95



**Southern** - Gondola Car w/Wheel Scrap Load  
20-98078 \$44.95



**Pittsburgh & Lake Erie** - Gondola Car w/Wheel Scrap Load  
20-98077 \$44.95



**Union Pacific**- Gondola Car w/Wheel Scrap Load  
20-98079 \$44.95

## Details

- O Scale Kadee® Compatible Mounting Pad
- Unit Measures: 14 5/8" x 2 5/8" x 3 15/16"
- Operates on O-31 Curves



# Coil Car



**Conrail** - Coil Car  
20-98644 \$49.95



**Kansas City Southern** - Coil Car  
20-98645 \$49.95



**Union Pacific** - Coil Car  
20-98647 \$54.95

**CHROME PLATED  
COVER**



**Norfolk Southern** - Coil Car  
20-98646 \$54.95

## Details

- O Scale Kadee® Compatible Mounting Pad
- Unit Measures: 13" x 2 1/2" x 3 3/4"
- Operates On O-54 Curves

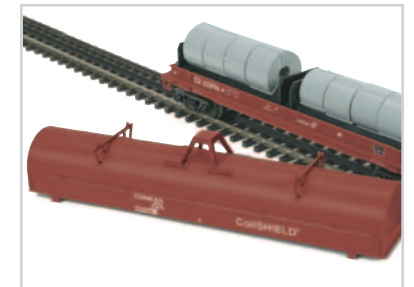

# Hot Metal Car w/Flickering Molten Load



**GCSX** - Hot Metal Car w/Flickering Molten Load **NEW!**  
20-98669 \$69.95



**ISCX** - Hot Metal Car w/Flickering Molten Load **NEW!**  
20-98671 \$69.95



**ISG** - Hot Metal Car w/Flickering Molten Load **NEW!**  
20-98670 \$69.95



**INLX** - Hot Metal Car w/Flickering Molten Load **NEW!**  
20-98672 \$69.95

## Details

- O Scale Kadee® Compatible Mounting Pad
- Flickering Molten Load
- Rotating Barrel
- Unit Measures: 15 1/4" x 2 3/4" x 3 5/8"
- Operates On O-31 Curves



# Husky Stack Car



**Canadian Pacific** - Husky Stack Car  
20-95075 \$59.95



**TTX** - Husky Stack Car  
20-95073 \$59.95



**BNSF** - Husky Stack Car  
20-95074 \$59.95



**Santa Fe** - Husky Stack Car  
20-95076 \$59.95

## Details

- O Scale Kadee® Compatible Mounting Pad
- Unit Measures: 18 3/4" x 2 9/16" x 5 9/16"
- Operates On O-54 Curves

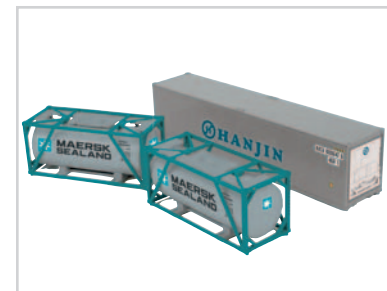

# 50-Ton 41' Wood Flat Car



**Northwestern Pacific** - 50-Ton 41' Wood Flat Car  
20-98653 \$39.95

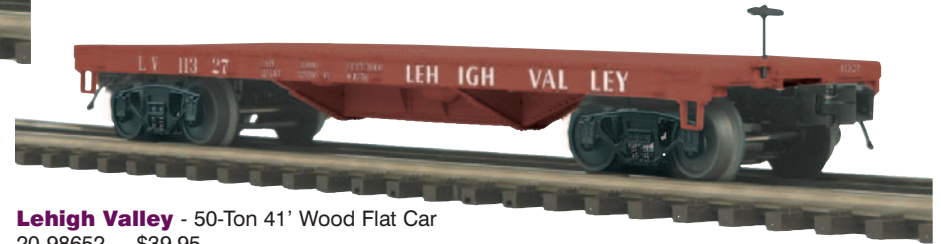

**Lehigh Valley** - 50-Ton 41' Wood Flat Car  
20-98652 \$39.95



**Reading** - 50-Ton 41' Wood Flat Car  
20-98654 \$39.95



**Duluth Missabe & Iron Range** - 50-Ton 41' Wood Flat Car  
20-98651 \$39.95

## Details

- O Scale Kadee® Compatible Mounting Pad
- Unit Measures: 11 3/4" x 2 1/2" x 1 1/16"
- Operates on O-31 Curves



# Center Beam Flat Car



**Canadian Pacific** - Center Beam Flat Car  
20-98655 \$49.95



**Florida Central** - Center Beam Flat Car  
20-98656 \$49.95

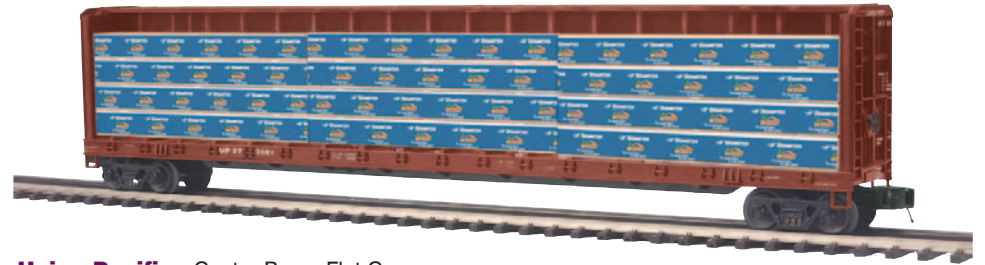

**Union Pacific** - Center Beam Flat Car  
20-98658 \$49.95

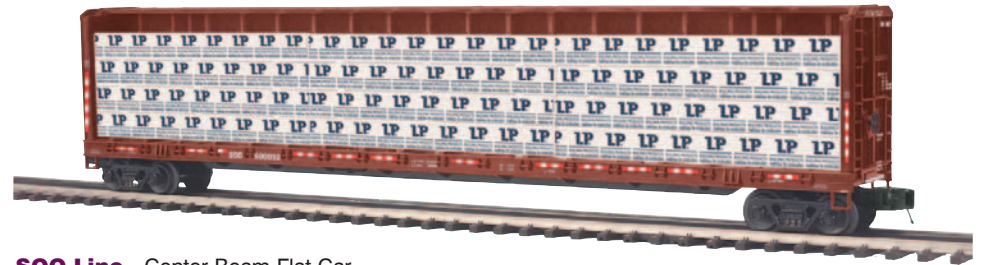

**SOO Line** - Center Beam Flat Car  
20-98657 \$49.95

## Details

- O Scale Kadee® Compatible Mounting Pad
- Unit Measures: 20" x 2 3/8" x 4 3/8"
- Operates On O-42 Curves





# Flat Car w/Bulkheads w/Covered Wood Load



**TTX** - Flat Car w/Bulkheads w/Covered Wood Load  
20-98662 \$49.95



**BNSF** - Flat Car w/Bulkheads w/Covered Wood Load  
20-98659 \$49.95

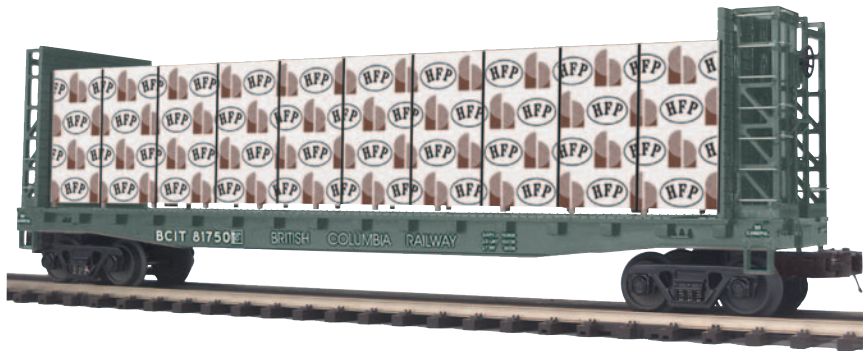

**British Columbia Railway** - Flat Car w/Bulkheads w/Covered Wood Load  
20-98660 \$49.95



**Montana Rail Link**- Flat Car w/Bulkheads w/Covered Wood Load  
20-98661 \$49.95

## Details

- O Scale Kadee® Compatible Mounting Pad
- Unit Measures: 14 5/8" x 2 3/4" x 4"
- Operates on O-31 Curves



# Flat Car w/Bulkheads & Pipe Load



**New Haven** - Flat Car - w/Bulkheads & Pipe Load  
20-98665 \$49.95



**Milwaukee Road** - Flat Car - w/Bulkheads & Pipe Load  
20-98664 \$49.95



**Alaska** - Flat Car - w/Bulkheads & Pipe Load  
20-98663 \$49.95



**Norfolk Southern** - Flat Car - w/Bulkheads & Pipe Load  
20-98666 \$49.95

## Details

- O Scale Kadee® Compatible Mounting Pad
- Unit Measures: 14 5/8" x 2 3/4" x 4"
- Operates On O-31 Curves



# Flat Car w/Load



**Caterpillar®** - 60' Flat Car w/(3) CAT 906 Compact Wheel Loaders  
20-98649 \$89.95



**Caterpillar®** - 60' Flat Car w/(1) CAT AD45B Articulated Truck  
20-98650 \$89.95



**Caterpillar®** - 60' Flat Car w/(2) CAT No. 977 Traxcavators  
20-98648 \$89.95

© 2008 Caterpillar  
CAT, CATERPILLAR, their respective logos, "Caterpillar Yellow" and the POWER EDGE trade dress, as well as corporate and product identity used herein, are trademarks of Caterpillar and may not be used without permission.

## Details

- O Scale Kadee® Compatible Mounting Pad
- Unit Measures: 15" x 2 11/16" x 3 3/4"
- Operates On O-42 Curves

### Quality, Detailed Cat Loads With Moving Parts



# Extended Vision Caboose



**SOO Line** - Extended Vision Caboose  
20-91275 \$59.95



**Great Northern** - Extended Vision Caboose  
20-91274 \$59.95

## Details

- Lighted Detailed Interior
- Unit Measures: 10 3/4" x 2 3/4" x 4"
- Operates on O-31 Curves



**Grand Trunk Western** - Extended Vision Caboose  
20-91273 \$59.95



**Canadian Pacific** - Extended Vision Caboose  
20-91272 \$59.95



# N-8 Caboose



**Penn Central** - N-8 Caboose  
20-91279 \$59.95



**Illinois Central Gulf** - N-8 Caboose  
20-91277 \$59.95



**Conrail** - N-8 Caboose  
20-91276 \$59.95



**Pennsylvania** - N-8 Caboose  
20-91278 \$59.95

## Details

- Lighted Detailed Interior
- Unit Measures: 9 5/8" x 2 1/2" x 3 15/16"
- Operates on O-31 Curves



# Bobber Caboose

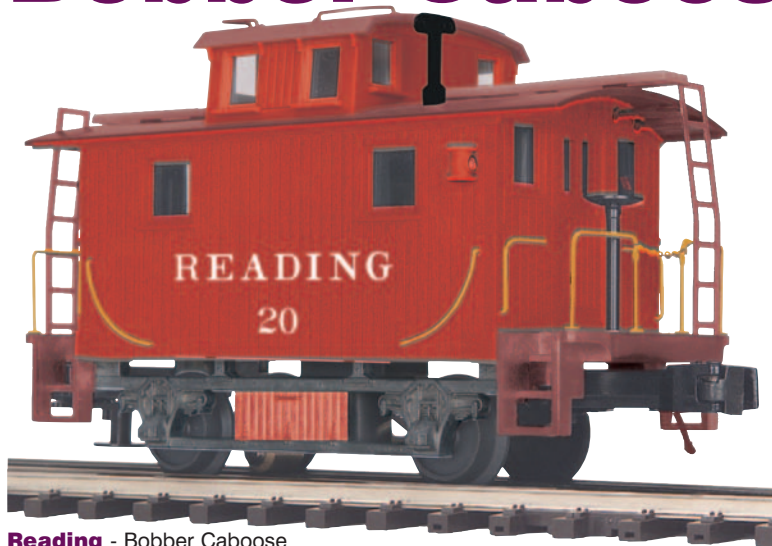

**Reading** - Bobber Caboose  
20-91268 \$44.95



**Lehigh Valley** - Bobber Caboose  
20-91270 \$44.95



**Canadian Pacific** - Bobber Caboose  
20-91269 \$44.95



**Union Pacific** - Bobber Caboose  
20-91271 \$44.95

## Details

- Lighted Detailed Interior
- Unit Measures: 6 5/8" x 2 5/8" x 3 1/2"
- Operates On O-27 Curves



# Bay Window Caboose



**Kansas City Southern** - Bay Window Caboose **CHROME PLATED**  
20-91265 \$69.95



**CSX** - Bay Window Caboose  
20-91264 \$59.95



**Norfolk Southern** - Bay Window Caboose  
20-91266 \$59.95



**Erie** - Bay Window Caboose  
20-91267 \$59.95

## Details

- Lighted Detailed Interior
- Unit Measures: 10 7/8" x 2 15/16" x 3 13/16"
- Operates on O-31 Curves



# 6-Car Coalporter Hopper Car Set



## Burlington Northern- 6-Car Coalporter Hopper Car Set

20-90443 (#'S 535021, 535029, 535018, 535012, 535017, 535024) \$279.95

20-90444 (#'S 535059, 535041, 535035, 535044, 535032, 535020) \$279.95



## CSX- 6-Car Coalporter Hopper Car Set

20-90445 (#'S 380177, 380276, 380846, 383556, 384442, 380076) \$279.95



## CSX- 6-Car Coalporter Hopper Car Set

20-90446 (#'S 380178, 380895, 380351, 385397 Summer Spike, 380122, 380102) \$279.95 Summer Spike



## Norfolk Southern- 6-Car Coalporter Hopper Car Set

20-90447 (#'S 10538, 10542, 10547, 10523, 10589, 10470) \$279.95

20-90448 (#'S 10530, 10545, 10543, 10521, 10588, 10474) \$279.95



## Union Pacific- 6-Car Coalporter Hopper Car Set

20-90449 (#'S 288214, 288156, 288169, 288198, 288187, 288170) \$279.95

20-90450 (#'S 288228, 288157, 288166, 288190, 288185, 288172) \$279.95

## Details

- Rotating Coupler For Rotary Dump Operations
- O Scale Kadee® Compatible Mounting Pad
- Unit Measures: 13 1/8" x 2 5/8" x 3 3/8"
- Operates on O-31 Curves





# 6-Car 3-Bay Centerflow Hopper Car Set



## Kansas City Southern - 6-Car 3-Bay Centerflow Hopper Car Set

20-90439 (#'S 286003, 286014, 286022, 286124, 286017, 286009) \$249.95  
 20-90440 (#'S 286010, 286016, 286128, 286142, 286133, 286139) \$249.95



## BNSF - 6-Car 3-Bay Centerflow Hopper Car Set

20-90435 (#'S 484006, 484012, 484015, 484008, 484027, 484023) \$249.95  
 20-90436 (#'S 484930, 484927, 484921, 484938, 484942, 484934) \$249.95



## CSX - 6-Car 3-Bay Centerflow Hopper Car Set

20-90437 (#'S 265110, 265014, 265029, 265032, 265025, 265106) \$249.95  
 20-90438 (#'S 265162, 265168, 265174, 265150, 265171, 265165) \$249.95



## Norfolk Southern - 6-Car 3-Bay Centerflow Hopper Car Set

20-90441 (#'S 292538, 292534, 292540, 292547, 292543, 292559) \$249.95  
 20-90442 (#'S 292552, 292556, 292560, 292568, 292611, 292573) \$249.95

## Details

- O Scale Kadee® Compatible Mounting Pad
- Unit Measures: 13 7/8" x 2 11/16" x 3 7/8"
- Operates on O-31 Curves



# Premier Passenger Cars: CHECK OUT THE DETAILS!



It's hard to match the excitement and beauty of a long, sleek passenger train speeding down the rails and M.T.H. has you covered with six different styles for virtually any passenger era.

If you haven't handled a Premier passenger car lately, take another look. We've upgraded the detail level, populated the interiors, and redesigned our trucks with details worthy of an expensive brass model. New this catalog is a plated finish on our models of prototype stainless steel cars, to replicate the gleaming finish of some of the great streamlined trains.

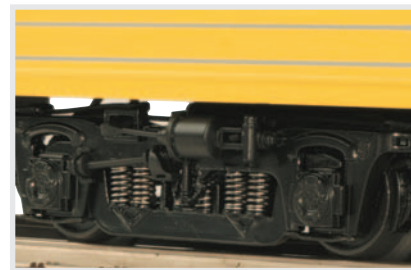

## Features

- Durable ABS Intricately Detailed Bodies
- Metal Wheels and Axles
- Overhead Interior Lighting
- Die-Cast 4-Wheel Trucks
- Operating Die-Cast Metal Couplers
- Colorful, Attractive Paint Schemes
- End-of-Car Diaphragms
- Separate Metal Handrails
- Fast-Angle Wheel Sets
- Needle-Point Axles
- Detailed Car Interiors
- 10 Passenger Figures In Each Coach Car
- 1:48 Scale Dimensions
- Detailed Car Undercarriage
- Sliding Baggage Car Doors

# Woodsided Passenger Set

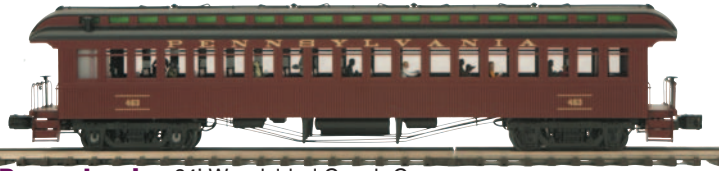

**Pennsylvania** - 64' Woodsided Coach Car  
20-62018 \$89.95



**Pennsylvania** - 3-Car 64' Woodsided Passenger Set  
20-62017 \$259.95



**Long Island** - 3-Car 64' Woodsided Passenger Set  
20-62021 \$259.95



**Strasburg** - 64' Woodsided Coach Car  
20-62016 \$89.95

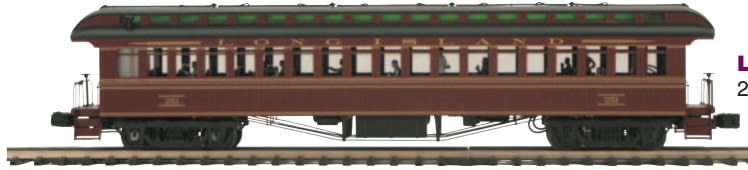

**Long Island** - 64' Woodsided Coach Car  
20-62022 \$89.95



**Strasburg** - 3-Car 64' Woodsided Passenger Set  
20-62015 \$259.95



**Baltimore & Ohio** - 3-Car 64' Woodsided Passenger Set  
20-62019 \$259.95

## Woodsided Details

- 3-Car Sets Features (3) Coaches
- 3-Car Set Measures: 51 5/8" x 2 1/2" x 3 5/8"
- Coach Measures: 18 1/4" x 2 1/2" x 3 5/8"
- Operates On O-42 Curves



**Baltimore & Ohio** - 64' Woodsided Coach Car  
20-62020 \$89.95

# Premier Passenger Cars

## Orient Express Passenger Set



**NEW!** 5-Car Orient Express Passenger Set  
20-60004 \$499.95



# Amfleet Passenger Set



**Amtrak** - 4-Car Amfleet Passenger Set  
20-65142 \$324.95



**Amtrak** - 2-Car Amfleet Passenger Set  
20-66142 \$169.95



**Amtrak** - 4-Car Amfleet Passenger Set  
20-65143 \$324.95



**Amtrak** - 2-Car Amfleet Passenger Set  
20-66143 \$169.95



**Septa** - 4-Car Amfleet Passenger Set  
20-65139 \$324.95



**Septa** - 2-Car Amfleet Passenger Set  
20-66139 \$169.95



**MARC** - 4-Car Amfleet Passenger Set  
20-65141 \$324.95



**MARC** - 2-Car Amfleet Passenger Set  
20-66141 \$169.95

## Amfleet Details

- 2-Car Sets Feature (2) Coaches
- Unit Measures: 38" x 2 1/2" x 3 1/4"
- Operates On O-42 Curves



# Madison Passenger Cars

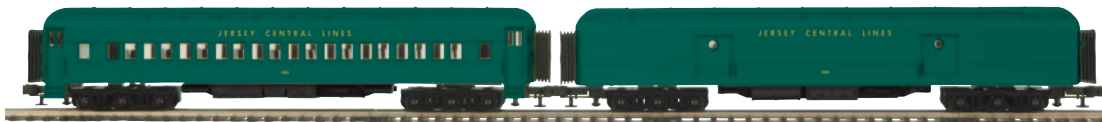

**Jersey Central** - 2-Car 70' Madison Baggage/Coach Passenger Set  
20-4497 \$159.95

**Jersey Central** - 2-Car 70' Madison Comb/Din Passenger Set  
20-4197 \$159.95

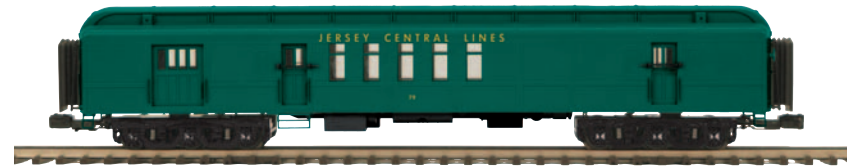

**Jersey Central** - 70' Madison RPO Passenger Car  
20-4297 \$89.95

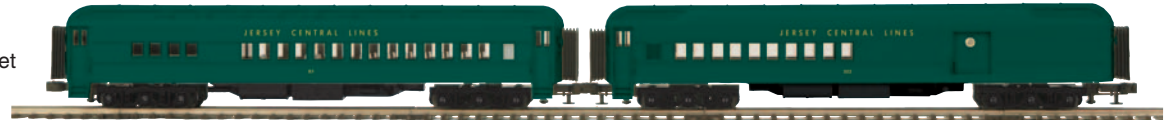

**Jersey Central** - 5-Car 70' Madison Passenger Set  
20-4097 \$399.95



**New York Ontario & Western** - 5-Car 70' Madison Passenger Set  
20-4098 \$399.95



**New York Ontario & Western** - 2-Car 70' Madison Baggage/Coach Passenger Set  
20-4498 \$159.95



**New York Ontario & Western** - 70' Madison RPO Passenger Car  
20-4298 \$89.95

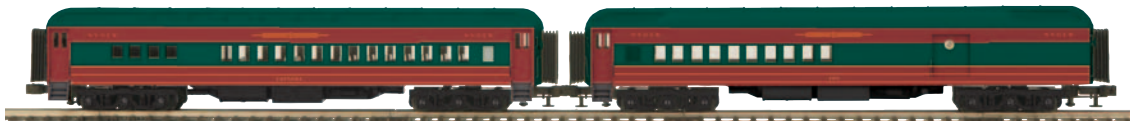

**New York Ontario & Western** - 2-Car 70' Madison Comb/Din Passenger Set  
20-4198 \$159.95



**Reading** - 70' Madison RPO Passenger Car  
20-4299 \$89.95

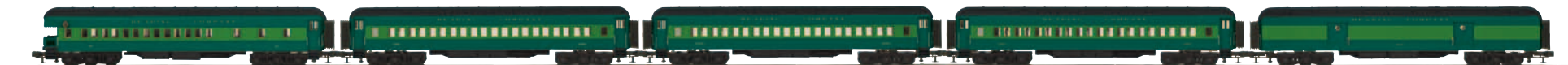

**Reading** - 5-Car 70' Madison Passenger Set  
20-4099 \$399.95



**Reading** - 2-Car 70' Madison Baggage/Coach Passenger Set  
20-4499 \$159.95

## Madison Details

- 5-Car Sets Feature (1) Baggage, (3) Coaches, (1) Observation
- 4-Car Set Measures: 95" x 2 7/16" x 3 1/2"
- 2-Car Set Measures: 38" x 2 7/16" x 3 1/2"
- Coach Car Measures: 19" x 2 7/16" x 3 1/2"
- Operates On O-42 Curves

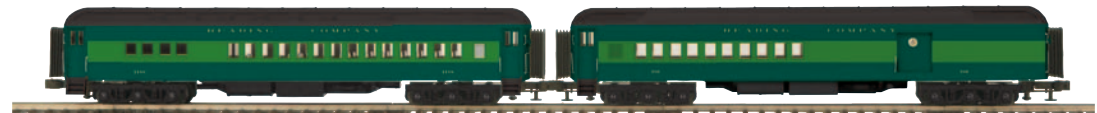

**Reading** - 2-Car 70' Madison Comb/Din Passenger Set  
20-4199 \$159.95

# Streamlined Passenger Cars

**Alaska** - 70' ABS RPO Passenger Car (Smooth)  
20-68130 \$89.95



**Alaska** - 70' ABS Full Length Vista Dome Passenger Car (Smooth)  
20-67130 \$89.95



**Alaska** - 2-Car 70' ABS Slpr/Diner Passenger Set (Smooth)  
20-66130 \$159.95



**Alaska** - 5-Car 70' ABS Passenger Set (Smooth)  
20-65130 \$399.95



**Alaska** - 2-Car 70' ABS Baggage/Coach Passenger Set (Smooth)  
20-69130 \$159.95



**Santa Fe** - 2-Car 70' ABS Baggage/Coach Passenger Set (Smooth)  
20-69136 \$159.95



**Santa Fe** - 70' ABS Full Length Vista Dome Passenger Car (Smooth)  
20-67136 \$89.95



**Santa Fe** - 70' ABS RPO Passenger Car (Smooth)  
20-68136 \$89.95

**NEW! PLATED EXTERIOR FINISH**

**Santa Fe** - 2-Car 70' ABS Slpr/Diner Passenger Set (Smooth)  
20-66136 \$159.95

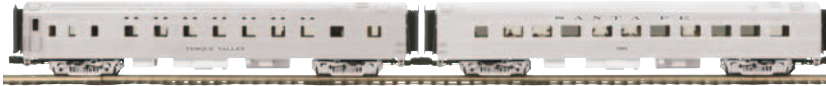

**Santa Fe** - 5-Car 70' ABS Passenger Set (Smooth)  
20-65136 \$399.95



**Baltimore & Ohio** - 5-Car 70' ABS Passenger Set (Smooth)  
20-65132 \$399.95



**Baltimore & Ohio** - 2-Car 70' ABS Baggage/Coach Passenger Set (Smooth)  
20-69132 \$159.95



**Baltimore & Ohio** - 2-Car 70' ABS Slpr/Diner Passenger Set (Smooth)  
20-66132 \$159.95



**Baltimore & Ohio** - 70' ABS RPO Passenger Car (Smooth)  
20-68132 \$89.95



**Baltimore & Ohio** - 70' ABS Full Length Vista Dome Passenger Car (Smooth)  
20-67132 \$89.95



**Western Pacific** - 70' ABS Full Length Vista Dome Passenger Car (Smooth)  
20-67144 \$99.95



**Southern Pacific** - 70' ABS Full Length Vista Dome Passenger Car (Smooth)  
20-67143 \$99.95



**Western Pacific** - 2-Car 70' ABS Coach/Coach Passenger Set (Smooth)  
20-69144 \$179.95



**Southern Pacific** - 2-Car 70' ABS Coach/Coach Passenger Set (Smooth)  
20-69143 \$179.95



# Streamlined Passenger Cars



**MKT** - 70' ABS Full Length Vista Dome Passenger Car (Smooth)  
20-67142 \$99.95



**Missouri Pacific** - 2-Car 70' ABS Coach/Coach Passenger Set (Smooth)  
20-69141 \$179.95



**Union Pacific** - 70' ABS Baggage Car (Smooth)  
20-68002 \$119.95



**MKT** - 2-Car 70' ABS Coach/Coach Passenger Set (Smooth)  
20-69142 \$179.95



**Missouri Pacific** - 70' ABS Full Length Vista Dome Passenger Car (Smooth)  
20-67141 \$99.95

**Denver Rio Grande** - 70' ABS Full Length Vista Dome Passenger Car (Smooth)  
20-67140 \$99.95



**Denver Rio Grande** - 2-Car 70' ABS Coach/Coach Passenger Set (Smooth)  
20-69140 \$179.95



**Chicago NorthWestern** - 2-Car 70' ABS Coach/Coach Passenger Set (Smooth)  
20-69139 \$179.95



**Chicago NorthWestern** - 70' ABS Full Length Vista Dome Passenger Car (Smooth)  
20-67139 \$99.95



**VIA Rail** - 2-Car 70' ABS Baggage/Coach Passenger Set (Ribbed)  
20-69138 \$159.95



**VIA Rail** - 70' ABS RPO Passenger Car (Ribbed)  
20-68138 \$89.95

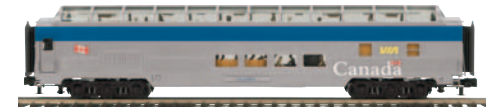

**VIA Rail** - 70' ABS Full Length Vista Dome Passenger Car (Ribbed)  
20-67138 \$89.95



**VIA Rail** - 5-Car 70' ABS Passenger Set (Ribbed)  
20-65138 \$399.95



**Burlington** - 70' ABS Full Length Vista Dome Passenger Car (Ribbed)  
20-67133 \$89.95



**Burlington** - 70' ABS RPO Passenger Car (Ribbed)  
20-68133 \$89.95



**VIA Rail** - 2-Car 70' ABS Slpr/Diner Passenger Set (Ribbed)  
20-66138 \$159.95



**Burlington** - 2-Car 70' ABS Baggage/Coach Passenger Set (Ribbed)  
20-69133 \$159.95

**NEW! PLATED EXTERIOR FINISH**



**Burlington** - 2-Car 70' ABS Slpr/Diner Passenger Set (Ribbed)  
20-66133 \$159.95



**Burlington** - 5-Car 70' ABS Passenger Set (Ribbed)  
20-65133 \$399.95





**Norfolk & Western** - 2-Car 70' ABS Baggage/Coach Passenger Set (Smooth)  
20-69145 \$159.95



**Norfolk & Western** - 2-Car 70' ABS Slpr/Diner Passenger Set (Smooth)  
20-66145 \$159.95



**Norfolk & Western** - 5-Car 70' ABS Passenger Set (Smooth)  
20-65145 \$399.95



**Norfolk & Western** - 70' ABS RPO Passenger Car (Smooth)  
20-68145 \$89.95



**Pennsylvania** - 2-Car 70' ABS Slpr/Diner Passenger Set (Smooth)  
20-66135 \$159.95

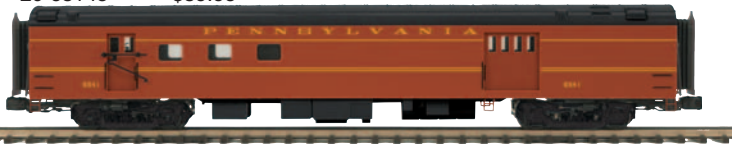

**Pennsylvania** - 70' ABS RPO Passenger Car (Smooth)  
20-68135 \$89.95



**Pennsylvania** - 2-Car 70' ABS Baggage/Coach Passenger Set (Smooth)  
20-69135 \$159.95



**Pennsylvania** - 5-Car 70' ABS Passenger Set (Smooth)  
20-65135 \$399.95



**Lackawanna** - 70' ABS Full Length Vista Dome Passenger Car (Smooth)  
20-67134 \$89.95



**Lackawanna** - 70' ABS RPO Passenger Car (Smooth)  
20-68134 \$89.95



**Pennsylvania** - 70' ABS Full Length Vista Dome Passenger Car (Smooth)  
20-67135 \$89.95



**Lackawanna** - 2-Car 70' ABS Slpr/Diner Passenger Set (Smooth)  
20-66134 \$159.95



**Lackawanna** - 2-Car 70' ABS Baggage/Coach Passenger Set (Smooth)  
20-69134 \$159.95



**Lackawanna** - 5-Car 70' ABS Passenger Set (Smooth)  
20-65134 \$399.95

## 4-8-4 GS-4/6 HO Steam Engine



In 1937 the Southern Pacific trumpeted a new train in full-page magazine ads:

*Let us stand by the tracks of Southern Pacific's Coast Line, as thousands now do every day and listen... Suddenly from far off comes a musical note, rising. Round a curve flashes a streak of color. Here comes the Daylight, the most beautiful train in the West!*

The Daylights linked Los Angeles and San Francisco "in a glorious daylight trip, streaking along the Pacific Ocean for more than a hundred breathless miles." Travelers were invited to "Step inside the Daylight and see the

beauty and luxury that have already won the West. Notice the wide, soft seats in the coaches. They are cushioned with sponge rubber and turn to face the extraordinarily large windows." Presenting a glorious streak of orange and red from locomotive to observation car, the Daylights were a sharp departure from the SP's normal dark olive passenger cars.

Leading the trains were the Southern Pacific's class GS (for "Golden State") Northern, arguably among the hand-somest steam engines ever built. Constructed by Lima Locomotive Works, inventor of the super-power concept, the Daylight 4-8-4s had the combination of power and

speed that characterized steam power at its zenith. Class GS-4 engines, delivered in 1941 and 1942, were among the last and best-looking of the breed, with tall 80" drivers and enclosed all-weather cabs. In addition to handling premier passenger trains, the Golden State 4-8-4s were regularly used in high-speed freight service on the San Francisco-Los Angeles Overnight.

A lone GS-4, No. 4449, was saved from the scrapper and restored in 1975 to pull the American Freedom Train in celebration of our nation's 200th anniversary. Repainted in Daylight colors, engine 4449 operates today in excursion service.

## Features

- Die-Cast Boiler and Tender Body
- Die-Cast Metal Chassis
- Authentic Paint Schemes & Cab Numbers
- RP-25 Metal Wheels Mounted On Metal Axles
- Constant Voltage Headlight
- Prototypical Rule 17 Lighting
- Detailed Truck Sides
- Detailed Cab Interior
- Powerful 5-Pole Precision Flywheel Equipped Motor
- (2) Scale Kadee® Compatible Couplers
- Metal Handrails and Bell
- Metal Whistle
- Sprung Drive Wheels
- Synchronized Puffing ProtoSmoke™ System
- Locomotive Speed Control In Scale MPH Increments
- Detailed Tender Undercarriage
- Interchangeable Traction Tire-Equipped Drive Wheels
- On-Board DCC Receiver
- Operates On Code 70, 83, & 100 Track
- Wireless Drawbar
- Engineer and Fireman Figures
- Operating Marker Lights\*
- Proto-Sound® 3.0 With The Digital Command System  
Featuring: Passenger StationProto-Effects™
- Unit Measures: 15 3/4" x 2 1/4" x 1 1/2"
- Operates On 22" Radius Curves

\*Patent Pending



**Southern Pacific** - 4-8-4 GS-6 Steam Engine  
80-3121-1 w/Proto-Sound 3.0 \$449.95  
Black - Large Tender Lettering, Cab Number 4460



**Southern Pacific** - 4-8-4 GS-6 Steam Engine  
80-3122-1 w/Proto-Sound 3.0 \$449.95  
Black - Small Tender Lettering, Cab Number 4466



**Western Pacific** - 4-8-4 GS-6 Steam Engine  
80-3120-1 w/Proto-Sound 3.0 \$449.95  
Cab Number 483

## DIE-CAST METAL



## Matching Passenger Cars Coming Soon!



**Southern Pacific** - 4-8-4 GS-4 Steam Engine  
80-3114-1 w/Proto-Sound 3.0 \$449.95  
Daylight - Small Tender Lettering, Cab Number 4453



**Southern Pacific** - 4-8-4 GS-4 Steam Engine  
80-3116-1 w/Proto-Sound 3.0 \$449.95  
Large Tender Lettering, Cab Number 4449



**BNSF** - 4-8-4 GS-4 Steam Engine  
80-3118-1 w/Proto-Sound 3.0 \$449.95  
Cab Number 4449



**American Freedom Train** - 4-8-4 GS-4 Steam Engine  
80-3119-1 w/Proto-Sound 3.0 \$449.95  
Cab Number 4449



**Southern Pacific** - 4-8-4 GS-4 Steam Engine  
80-3117-1 w/Proto-Sound 3.0 \$449.95  
Daylight - Small Tender Lettering, Cab Number 4449



**Southern Pacific** - 4-8-4 GS-4 Steam Engine  
80-3115-1 w/Proto-Sound 3.0 \$449.95  
Black, Cab Number 4437

# Transformers



While the power pack that comes with every RailKing Ready-To-Run set provides plenty of power to operate your set & several additional cars, you'll find as you add more track, cars, & accessories to your layout that you need more power to keep everything running. Fortunately, RailKing has you covered.

If you want to power up gradually, you can purchase additional 75-watt Z-750 or 100 watt Z-1000 transformers as the need arises. Featuring a U.L. approved design, each model utilizes a separate controller which contains bell, horn & direction buttons that can control any manufacturer's locomotives & sound systems including Proto-Sound equipped steam, diesel & electric locomotives.

If you want to max out your power potential, the 400-watt Z-4000 is the most powerful transformer to receive the UL-listing for the model railroading hobby. The Z-4000 has two separate throttles to let you power two different tracks, & it has two fixed power outputs you can use for operating accessories. A single Z-4000 will power a lot of layout.



**Z-1000™ Transformer**  
40-1000 \$99.95  
With 14 Volt Accessory Port

**100 Watt**



**Z-4000® Transformer**  
40-4000 \$429.95

**50 Watt**



**Z-500™ Transformer**  
40-500 \$59.95

To receive the latest updates on catalog items, sign up for our weekly e-newsletter. Go to the News link at the top of our home page, [www.mthtrains.com](http://www.mthtrains.com).

DCS users who don't need a conventional transformer and controller can use this 100 watt power supply for small and moderate sized layouts. Featuring a U.L. approved design & separate 14v AC Accessory Port, its robust design will provide years of service. Use the optional TIU/Barrel Jack adapter to make connecting it to the DCS Track Interface Unit quick and easy.



**100-Watt Accessory Power Supply**  
40-1000A \$79.95

## WHY THE U.L. LISTING?

M.T.H. Electric Trains is committed to manufacturing safe, U.L. approved transformers and power supplies. By subjecting our transformers to the strenuous tests and requirements of the U.L. laboratories, M.T.H. helps ensure that these products meet the same requirements as other consumer electronics sold today. When choosing a new transformer, model railroaders should only look for those that have received a U.L. listing.

# DCS Commander

## MORE FEATURES For Your M.T.H. Train Set

The next generation of the DCS Digital Command System is here. The all-new DCS Commander brings a less expensive, but powerful command control device to your O Gauge and HO DC powered layouts. Connect a DCS Commander between the wires of your existing DCC system or DC power supply to the track and you can switch back and forth between DCS and Analog DC operating modes with just a push of a button.

Because many M.T.H. Proto-Sound 2.0\*\* locomotives can operate on both AC or DC current, the DCS Commander may be the affordable DCS command control option you've been looking for. Available alone or bundled with a 100 watt power supply, The DCS commander outputs 18 volts of DC power and includes a built-in 5amp resettable breaker making it a perfect solution for small M.T.H. O Gauge layouts exclusively running Proto-Sound 2.0\*\* locomotives.

For HO operators, the DCS Commander Controller Set is a perfect power solution for almost any size HO layout. HO operators whose layouts are already outfitted with a DC power supply can choose the individual DCS Commander and plug their existing power supply right into the Commander's power inputs.

The DCS Commander provides the user with intuitive control of multiple Proto-Sound 2.0\*\* or later equipped locomotives. For each locomotive, more than 32 functions are available at the touch of a single clearly-labeled button.



**DCS Commander System  
w/100 Watt Power Supply**  
50-1029 \$229.95

### Features Include:

- Speed adjustment in one-scale mile-per-hour steps
- Independent feature control: tune your engines' sound, lights, smoke and acceleration/deceleration settings
- Smoke On/Off
- Doppler Sounds: simulate the classic sound effect of a train approaching and then whizzing past
- Accent Sounds: activate any one of 7 individual sounds, including signal forward and reverse sounds, coupler slack, engine start-up and shut-down, engine labor and engine drift
- Activate Passenger Station and Freight Yard Sounds
- Individual locomotive control: select up to 99 Proto-Sound 2.0 or later engines

- Selectable control mode configurations: choose between analog DC, DCC and DCS operating modes
- Track Signal Test: test your layout's signal strength using the built-in signal strength analyzer.
- Proto-Whistle Quillable Sound Activation: access the built-in Proto-Whistle quillable sounds\*\*\* found inside your Proto-Sound 2.0 or later locomotives and using the thumbwheel to "play" your locomotive's whistle just like a real engineer!
- Access Whistle Signal Sounds: activate grade crossing whistle signals\*\*\*\* on your Proto-Sound 2.0 or later equipped locomotive

\*\* Requires Proto-Sound 2.0 locomotive onboard 3-volt system or Proto-Sound 3.0 locomotive onboard system. Proto-Sound 2.0 3-volt systems are identified by their square battery charging jack on the locomotive chassis. See the locomotive's operator's manual for the exact location of the charging jack.

\*\*\* Proto-Whistle quillable sounds not found in all Proto-Sound 2.0 or later equipped locomotives. Refer to your locomotives operator's manual to determine if your locomotive is equipped with Proto-Whistle quillable sounds.

\*\*\*\*Proto-Whistle grade crossing signals not found in all Proto-Sound 2.0 or later equipped locomotives.

### Perfect for Any Proto-Sound 2.0 Equipped Train Set!



**DCS Commander Controller**  
50-1028 \$149.95

# Take Another Look at ScaleTrax™

ScaleTrax™ by M.T.H. Electric Trains is the ultimate track system that detail-oriented 3-rail modelers have been looking for. No longer will an O Gauge modeler have to accept excessively tall or heavy-looking track, because ScaleTrax offers maximum accuracy and the exceptional quality of M.T.H. products. It's perfect for creating an authentic looking 3-rail layout.

**COMPARE** ScaleTrax with other 3-rail track systems and see what we have to offer:

## More Realism

Prototypically scaled, lower-profile rail and ties make your locomotives and rolling stock look more massive on ScaleTrax.

## Smaller Third Rail

The thinnest, lowest-profile center rail of any major track brand gives ScaleTrax a more prototypical look.

## Better Electrical Contact

Concealed, large, spring-loaded contacts deliver more secure electrical connections between track sections.

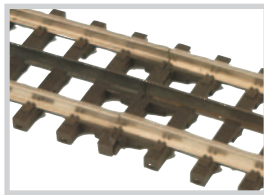
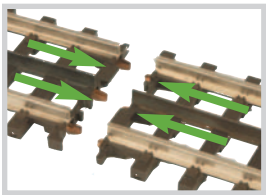
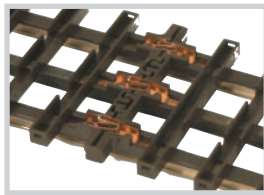
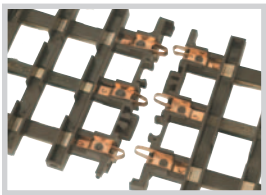

**Easy Snap-Together Assembly**

## Smoother Switches

Thanks to our ramped and beveled frog, ScaleTrax offers the smoothest-rolling switches in O gauge.

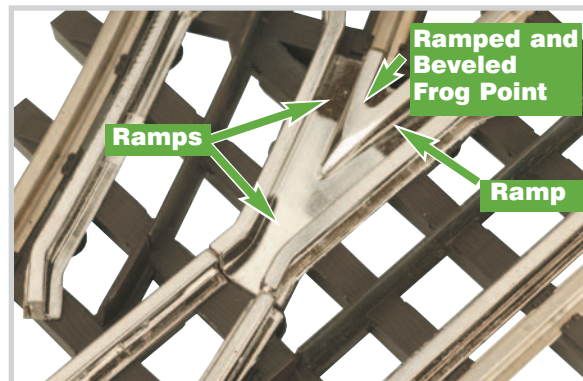

## Easier-to-use Flex Track

Low-profile rail and ties make ScaleTrax flex easier to bend without kinking.

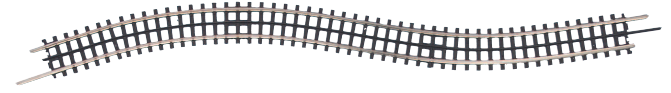



**SCALETRAX**<sup>™</sup>  
BY M.T.H. ELECTRIC TRAINS

### Learn More About It

View our comprehensive ScaleTrax FAQ at:

**WWW.MTHTRAINS.COM**

### Track Features

- Solid, Rust-Proof Nickel Silver Track Rails
- Low-Profile Rail Height For A Realistic Appearance
- Durable, ABS Ties For Years of Use
- Snap-Together Assembly
- Built-In Electrical Connections Eliminate Need For Rail Joiners or Track Pins
- Assembles In Minutes Without Any Special Tools
- Built-In Lockon Connector Receptacle In Every Track Section
- Available In Wide Selection of Curves and Straight Sections
- Compatible With Most Manufacturers' Locomotives and Cars

Special thanks to Rich Battista of the Black Diamond Railway for sharing his layout photos. Learn more about Rich's layout and his Black Diamond Railway video and see more examples of ScaleTrax in action by visiting:  
**WWW.TOYTRAINSONTRACKS.COM**

### Snap-In Reversible Switch Motors

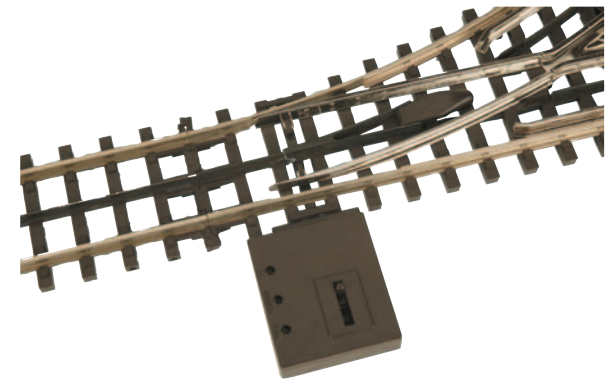
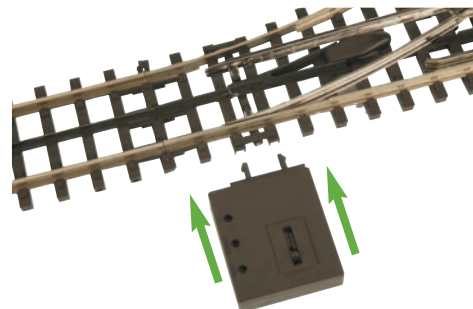
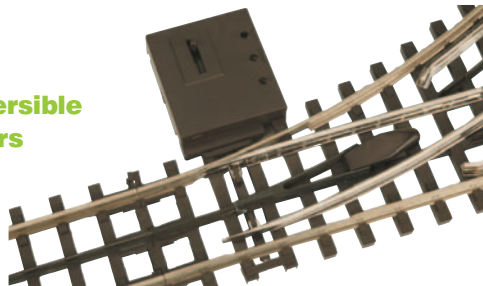

# ScaleTrax

## STRAIGHT, FLEX & OPERATING TRACK SECTIONS

It takes **EIGHT 0-31 CURVES** to make a circle.  
 It takes **TWELVE 0-42 CURVES** to make a circle.  
 It takes **TWELVE 0-54 CURVES** to make a circle.  
 It takes **SIXTEEN 0-72 CURVES** to make a circle.  
 It takes **SIXTEEN 0-82 CURVES** to make a circle.

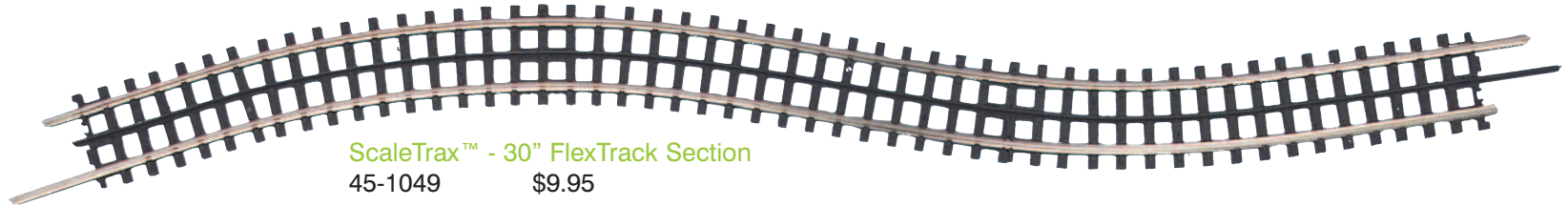
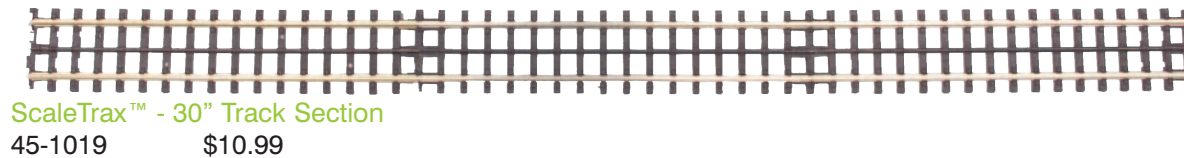
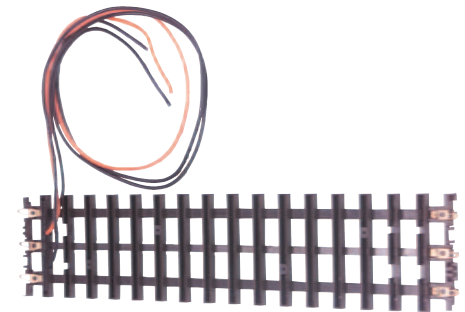
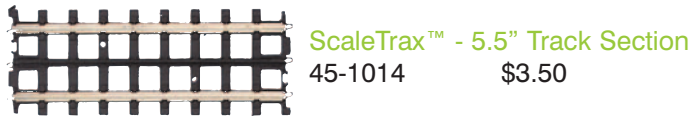
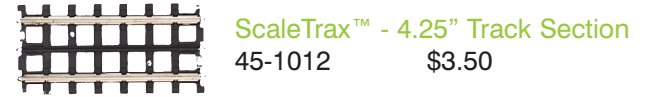
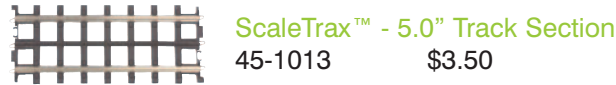

**Lowest Profile, Most Realistic 3-Rail Track in O Gauge!**

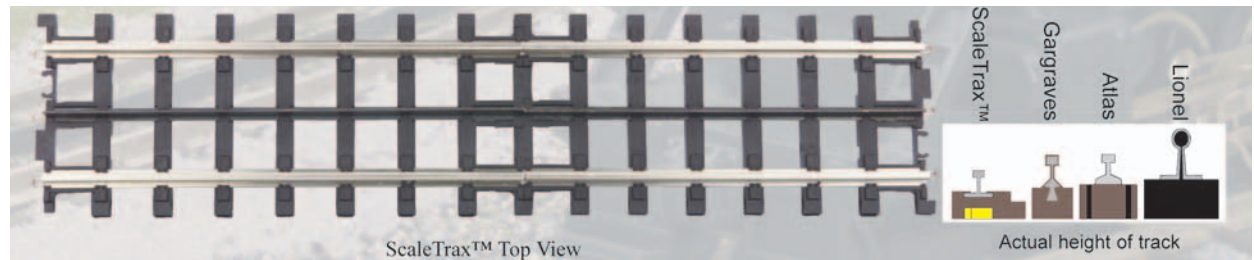



**CURVED TRACK SECTIONS**

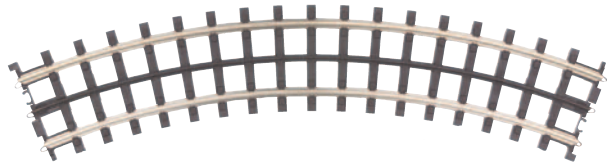

ScaleTrax™ - O-31 Curved Track Section  
45-1002 \$3.99

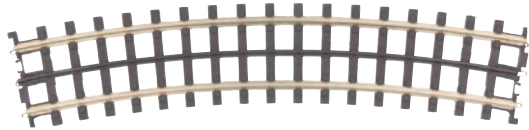

ScaleTrax™ - O-54 Curved Track Section  
45-1007 \$3.99

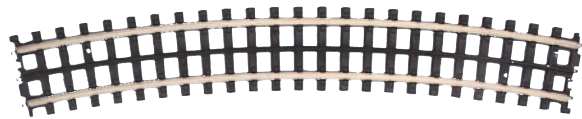

ScaleTrax™ - O-72 Curved Track Section  
45-1010 \$4.99

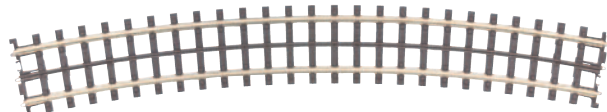

ScaleTrax™ - O-80 Curved Track Section  
45-1034 \$5.99

**CROSSOVERS**

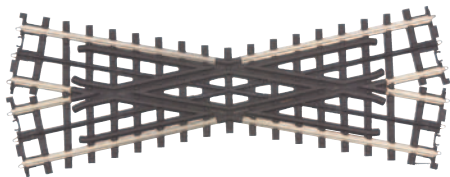

ScaleTrax™ - 22.5 Degree Crossing  
45-1015 \$19.95

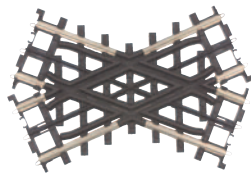

ScaleTrax™ - 45 Degree Crossing  
45-1006 \$19.95

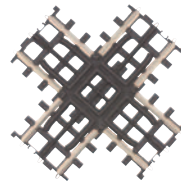

ScaleTrax™ - 90 Degree Crossing  
45-1005 \$19.95

**DIRECTIONAL SWITCHES**

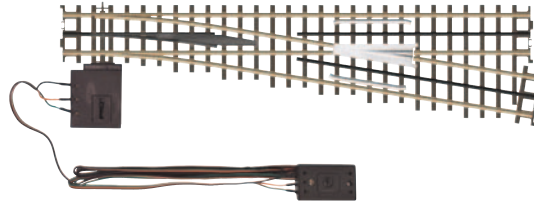

ScaleTrax™ - No. 6 Right Hand Switch  
45-1053 \$69.95

ScaleTrax™ - No. 6 Left Hand Switch  
45-1052 \$69.95

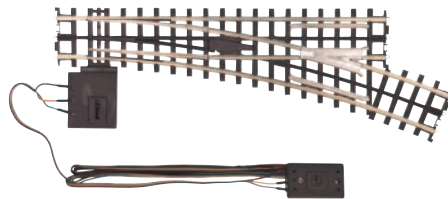

ScaleTrax™ - O-72 Right Hand Switch  
45-1020 \$49.95

ScaleTrax™ - O-72 Left Hand Switch  
45-1021 \$49.95

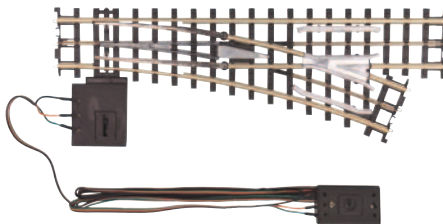

ScaleTrax™ - O-54 Right Hand Switch  
45-1009 \$49.95

ScaleTrax™ - O-54 Left Hand Switch  
45-1008 \$49.95

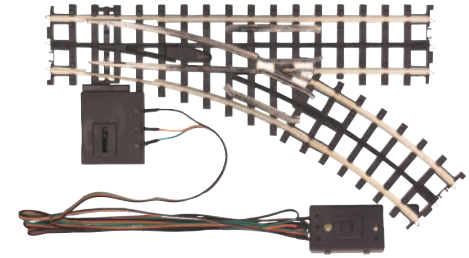

ScaleTrax™ - O-31 Right Hand Switch  
45-1004 \$49.95

ScaleTrax™ - O-31 Left Hand Switch  
45-1003 \$49.95

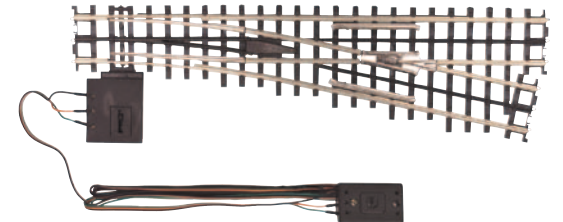

ScaleTrax™ - No. 4 Right Hand Switch  
45-1051 \$59.95

ScaleTrax™ - No. 4 Left Hand Switch  
45-1050 \$59.95

**ACCESSORIES**

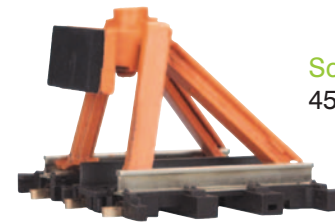

ScaleTrax™ - Bumper  
45-1025 \$15.95

ScaleTrax™ - ITAD  
45-1028 \$29.95



# PROTO-SCALE 3-2™

## Operate on 3-Rail or 2-Rail Track with AC or DC Power!

Many Premier steam and diesel engines in this catalog are equipped with Proto-Scale 3-2, a unique M.T.H. feature that allows you to run the same engine on 2-rail or 3-rail track, under AC or DC power. Engines cataloged with hi-rail wheels are intended primarily for 3-rail operators, while engines with scale wheels are aimed at 2-rail DC operators as well as 3-rail AC operators looking for more scale realism.

Each kit contains enough wheel sets for (2) power trucks. Wheels are polished, turned metal with scale treads and flange heights. Premounted on metal axles with one insulated side for use on 2-rail O Scale track systems. Two wheel sets in each kit contains premounted drive gears.

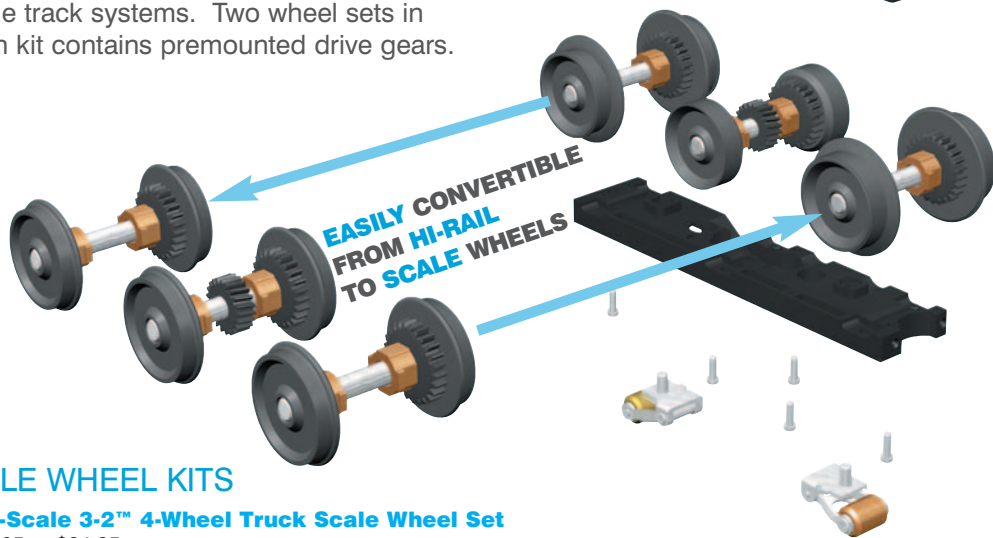

### SCALE WHEEL KITS

#### Proto-Scale 3-2™ 4-Wheel Truck Scale Wheel Set

20-89005 \$24.95

#### Proto-Scale 3-2™ 6-Wheel Truck Scale Wheel Set

20-89006 \$29.95

#### Proto-Scale 3-2™ 4-Wheel Truck Hi-Rail Wheel Set

20-89008 \$39.95

#### Proto-Scale 3-2™ 6-Wheel Truck Hi-Rail Wheel Set

20-89009 \$59.95

Each kit contains enough wheel sets for (1) power truck. Wheels are polished, turned metal with scale treads and flange heights. Premounted on metal axles with one insulated side for use on 2-rail O Scale track systems. One wheel set in each kit contains premounted drive gears.

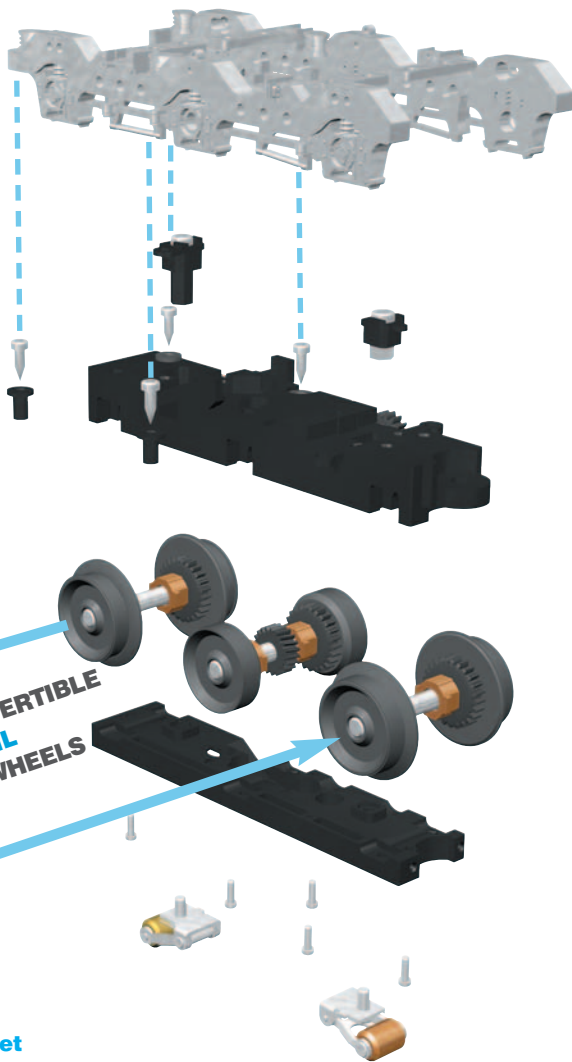

## End-of-Train-Device Roller Bearing Freight Truck

This long requested accessory can convert any M.T.H. Premier Line freight car to an end-of-train car in just a few minutes.

The all die-cast sprung loaded roller bearing truck includes a self-powered electronic circuit that powers a bright flashing LED resulting in an end-of-train effect found on modern freight drags.



The ETD truck easily mounts to your existing freight cars in just a few minutes.

### Features:

- Die-Cast Construction
- Fully Assembled
- Self-Powered Strobe Light
- Mounts To Any M.T.H. Freight Car
- Unit Measures: 1" High

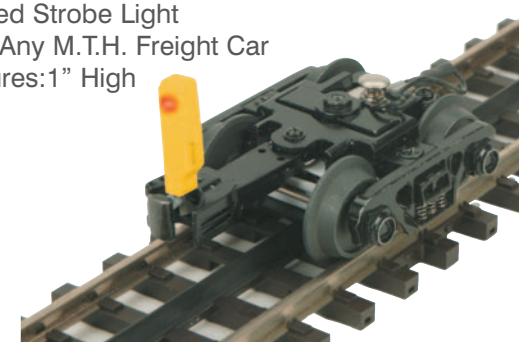

#### Yellow End-of-Train-Device Roller Bearing Freight Truck

20-89010 \$15.95

#### White End-of-Train-Device Roller Bearing Freight Truck

20-89013 \$15.95



#### Wireless Drawbar Set

20-89011 \$29.95

Owners of M.T.H. steam locomotives equipped with the wireless drawbar will find this set the perfect addition to their locomotive. Choose from three different lengths (30, 35, 40mm) of wireless drawbars to close-couple your locomotive for layouts equipped with wide-radius curves.

# O-Gauge Or Scale Couplers and Trucks

Many Premier Line freight cars come pre-equipped with mounting pads for Kadee® type scale couplers for those operators who want an even more realistic appearance for their rolling stock. A quick peek at the underside of the car will reveal whether the car is equipped with the mounting pad. In some cases, we've included coupler shims so that your scale couplers will be at prototypical height from the rails' surface.

When equipped with our 2-rail scale wheel freight car trucks (which don't come equipped with a standard O Gauge knuckle coupler) and a set of scale couplers, your affordable Premier Line freight car makes high priced brass scale freight cars a thing of the past.



## 3-RAIL

### 3-Rail Roller Bearing Freight Car Two Truck Pack

30-89002 \$12.99

### 3-Rail Bettendorf Freight Car Two Truck Pack

30-89001 \$12.99

### 3-Rail Roller Bearing Die-Cast Freight Car Two Truck Pack

20-89004 \$12.99

### 3-Rail Bettendorf Die-Cast Freight Car Two Truck Pack

20-89003 \$12.99

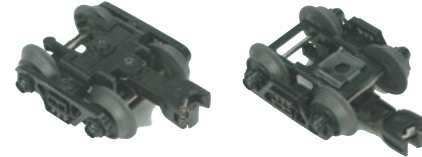

## 2-RAIL

### 2-Rail Lightweight Die-Cast Passenger Car Two Truck Pack

20-89007 \$24.95

### 2-Rail 64' Woodsided Passenger Car Two Truck

20-89012 \$24.95

### 2-Rail Bettendorf Die-Cast Freight Car Two Truck Pack

20-89001 \$12.99

### 2-Rail Roller Bearing Die-Cast Freight Car Two Truck Pack

20-89002 \$12.99

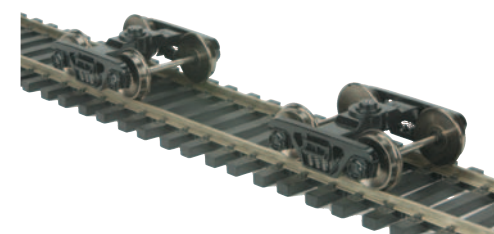
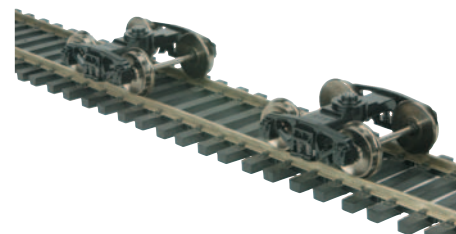
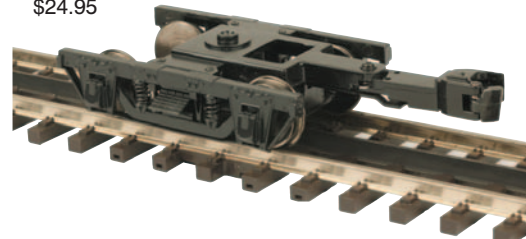
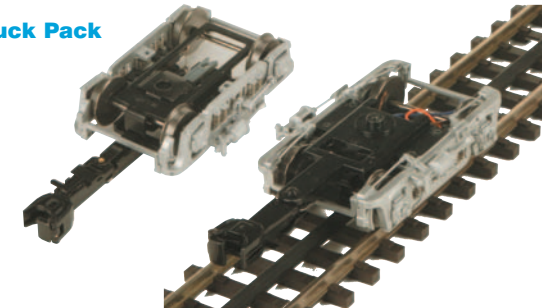

# Accessories



**Harley-Davidson®** - Lighted Billboard  
30-90285 \$29.95

HARLEY-DAVIDSON  
OFFICIAL LICENSED PRODUCT © 2008 H-D, All Rights Reserved.

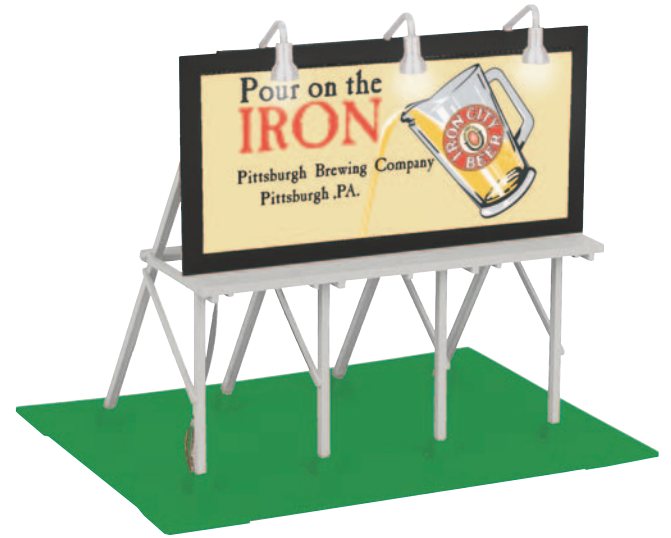

**Pittsburgh Brewing Co.** - Lighted Billboard  
30-90286 \$29.95

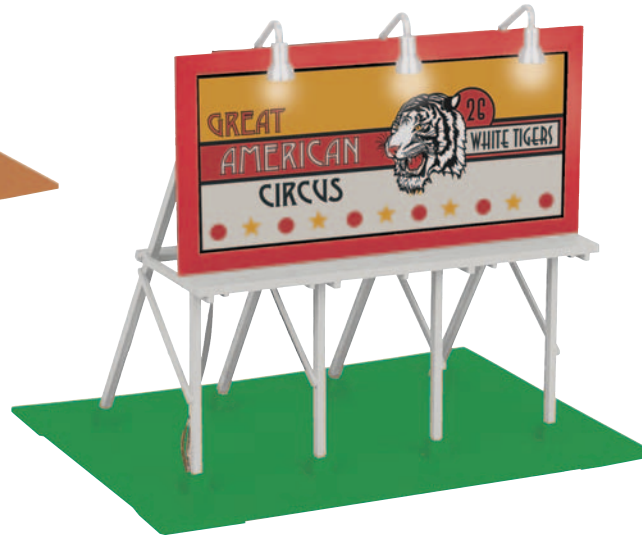

**Circus** - Lighted Billboard  
30-90287 \$29.95



**Rolling Rock** - Lighted Billboard  
30-90284 \$29.95

© 2008 Anheuser-Busch, Inc. All Rights Reserved.



**M&M'S®** - Lighted Billboard  
30-90283 \$29.95

®/™ M&M'S, the letter M and the M&M'S Characters are registered trademarks of Mars, Incorporated and its affiliates.  
©MARS, Incorporated 2008



**M&M'S®**  
 #193 Industrial Water Tower  
 30-90288 \$59.95

®/™ M&M'S, the letter M and the M&M'S Characters are registered trademarks of Mars, Incorporated and its affiliates. ©MARS, Incorporated 2008



**Coors**  
 #193 Industrial Water Tower  
 30-90291 \$59.95

© 2008 Molson Coors Global Properties, LLC Coors trademarks are properties of Molson Coors Global Properties, LLC, used under license by M.T.H. Electric Trains Limited Edition Adult Collectible-This licensed product is intended for purchase and enjoyment by individuals of legal purchase age for alcohol beverages.



**7UP**  
 #193 Industrial Water Tower  
 30-90290 \$59.95

7UP is a trademark of Dr Pepper/Seven Up, Inc., used by M.T.H. Electric Trains under license. ©2008 Dr Pepper/Seven up, Inc.



**Dr Pepper**  
 #193 Industrial Water Tower  
 30-90289 \$59.95

DR PEPPER is a trademark of Dr Pepper/Seven Up, Inc., used by M.T.H. Electric Trains under license. ©2008 Dr Pepper/Seven up, Inc.



**Shell** - Country Gas Station  
 30-90300 \$49.95



**Esso** - Country Gas Station  
 30-90301 \$49.95

# Accessories



**Fishing Hole Bait & Tackle** - Road Side Stand  
30-90295 \$39.95



**Regina's Soft Ice Cream**  
Road Side Stand  
30-90293 \$39.95



**Big Cletus' Bar-B-Que** - Road Side Stand  
30-90294 \$39.95



**Full Throttle Bar & Grill**  
Road Side Stand  
30-90292 \$39.95

## Opening Side Doors



## Interior Illumination



**Budweiser** - Vendor Trailer  
30-50042 \$29.95

"© 2008 Anheuser-Busch, Inc. All Rights Reserved."



**NEW!**  
**Valley Hardware** - Country Store  
 30-90299 \$44.95



**NEW!**  
**Railtown General Store** - Country Store  
 30-90298 \$44.95



**NEW!**  
**Maroon/Cream** - Country Passenger Depot  
 30-90303 \$49.95



**NEW!**  
**Dockside Bill's Seafood** - Small Country Store  
 30-90296 \$39.95



**NEW!**  
**Louie's Philly Style Subs** - Small Country Store  
 30-90297 \$39.95



**NEW!**  
**Tan/Green** - Country Passenger Depot  
 30-90302 \$49.95

# Club

## Join The Club

There are SIX different types of memberships, based on the style of model railroading that most interests you.

### RAILKING MEMBERSHIP



30-74488 MTHRRRC 34' Box Car - 19th Century  
**RailKing Membership is \$50.00**



### PREMIER MEMBERSHIP



20-91263 Chessie Steel Caboose  
**Premier Membership is \$50.00**



### ONE-GAUGE MEMBERSHIP



70-77028 Santa Fe Offset Steel Caboose  
**One-Gauge Membership is \$100.00**



### TINPLATE STD. GAUGE MEMBERSHIP



10-2231 MTHRRRC 500 Series Std. Gauge Box Car  
**Tinplate 500 Series Membership is \$120.00**



### TINPLATE O GAUGE MEMBERSHIP



10-8075 MTHRRRC 2800 Series O Gauge Caboose  
**Tinplate 2800 Series Membership is \$80.00**



### BASIC CLUB MEMBERSHIP

60-1000 - The Basic Club Membership does not include a club car  
**Basic Membership is \$25.00**



## GET THE MOST FROM MODEL RAILROADING

JOIN ONLINE! IT'S EASY - JUST GO TO [WWW.MTHTRAINS.COM](http://WWW.MTHTRAINS.COM)



## AS A MEMBER OF THE M.T.H. RAILROADERS CLUB YOU'LL RECEIVE:

### Limited-Edition Club Car



Each year we produce beautifully decorated cars exclusively for our Club members. Members automatically receive the car that matches their Club membership (RailKing, Premier, Tinplate Traditions or One Gauge) & have the option to collect the other Club cars as well.

### The CrossingGate™ Club Magazine

You will receive our full color Club magazines, jam-packed with product news, ideas from other members, rail history, & step-by-step articles explaining how M.T.H. technology can bring your railroad to life.



### 1st Class Mailing of M.T.H. Catalogs

Club Members get all of our catalogs earlier than all our other mailing list members via First-Class mailings, so they can order from their local train store before the best items are sold out.



### RailWare™ Software



Use your computer to design track layouts, search the database of all M.T.H. products, look at our past catalogs, listen to Proto-Sound 2.0 train effects, & much more. This CD retails for \$79.95, but is yours FREE as a Club member.

### Club Card & Lapel Pin



Show the world your membership in this elite group of model railroaders with your high-quality embossed membership card & beautiful enamel lapel pin.

### Proto-Sound® 2.0 Upgrade Kits

Club members can save an additional 15% on these kits by visiting the MTHRRRC web page.

### Club Web Site

Visit [www.MTHTRAINS.COM](http://www.MTHTRAINS.COM) & type in your member number to gain access to the Club web site. Here you can exchange messages with other Club members, keep up with the latest news, & even build your own homepage.

## CARRY ON THE M.T.H. TRADITION WITH MEMORABILIA AND COLLECTIBLES

### MTH Promotional DVD



This interactive DVD is packed full of sights & sounds guaranteed to make you rethink how far the hobby of model railroading has come. You'll learn about some of the most innovative products ever produced & marvel at the sophistication of a product line unmatched by other model train manufacturers.

### Previous Year Club Cars



MTHRRRC members can still obtain earlier produced MTHRRRC cars by visiting the MTHRRRC pages on the website. Only MTHRRRC members can get these cars!

### A Toy Train Story



This comprehensive book is a must for collectors & other lovers of toy trains. 350 pages & 1900 color photos, hard cover. Add this book to your membership for only \$25.00 (50% off the \$49.95 cover price)!

# M.T.H. Megastations

There are over 1,100 M.T.H. Authorized Retailers in North America ready to serve your model railroading needs. Of these, a select few qualify for inclusion in M.T.H.'s Mega Station program. So just what is a Mega Station?

Simply put, M.T.H. Authorized Mega Stations are your best bet for finding the widest selection of M.T.H. products in stock, when you want them. Mega Station retailers also meet our DCS Demo Center qualifications so you'll find expert assistance in seeing M.T.H. products in action whenever you visit a Mega Station retailer.

Each of our Mega Station dealers has the option of qualifying for one or more categories covering our RailKing O Gauge, Premier Line O Scale, Tinplate Traditions and RailKing One Gauge product lines.

The list to the right includes our current RailKing and Premier O Gauge Mega Station accounts. Of course, if your favorite M.T.H. Authorized Retailer isn't listed, they can still order any of our current offerings. To find a local M.T.H. Authorized Retailer, visit our Web site and click on the Dealer Locator link.

Not all products depicted in this catalog are production models. In some cases, the items pictured may be models in HO scale, O scale, or another scale that have been altered digitally.

Each item's graphic features and content are subject to change after publication. All product features may be verified on their retail packages.

M.T.H. Electric Trains is in no way affiliated with any of the railroads featured in this catalog.

©2008, M.T.H. Electric Trains, 7020 Columbia Gateway Drive, Columbia Maryland 21046-1532  
www.mthtrains.com • 410-381-2580

MTH Trademarks: M.T.H. Electric Trains®, M.T.H.®, MTH Railroaders Club™, CrossingGate™, Ives®, Loco-Sound™, Proto-Sound® 2.0, Proto-Speed Control™, Proto-Doppler™, Proto-Dispatch™, Proto-Cast™, ProtoSmoke™, Proto-Coupler™, Proto-Effects™, RailKing®, Rugged Rails®, RailKing One-Gauge™, RailTown™, Tinplate Traditions™, ScaleTrax™, RealTrax®, Z-750™, Z-4000®, Z-1000™, DCS™ and the MTH Numbering System and all others indicated throughout this catalog.

DCS™ Simply The Best Way To Run A Railroad™

M.T.H.'s DCS Digital Command System has received U.S. Patent No. 6,457,681. M.T.H.'s Proto-Sound® 2.0 system has received U.S. Patent No's 6,457,681 B1 (sound system), 6,457,681 B1 (Proto-Speed Control™), 6,604,641 (Proto-Coupler™), 7,210,656 (Sound), 6,662,917 (2/3Rail), 7,210,656 (Internet Downloads, Music & Doppler).

M.T.H.'s RealTrax® has received U.S. Patent No. 6,019,289.

M.T.H.'s Z-4000® Transformer has received U.S. Patent No's. 6,281,606 & 6,624,537.

Some images used in this publication © 2008 www.clipart.com

## ARIZONA

ARIZONA TRAIN DEPOT  
Mesa  
Phone: (480) 833-9486  
www.arizonatraindepot.com  
**O GAUGE**

## CALIFORNIA

TRAIN SHACK  
Burbank  
Phone: (818) 842-3330  
www.trainshack.com  
**O GAUGE**

## WESTERN DEPOT

Yuba City  
Phone: (530) 673-6776  
www.westerndepot.com  
**TINPLATE**

## DELAWARE

JUST TRAINS  
Newark  
Phone: (888) 453-9742  
www.justtrains.com  
**O GAUGE, TINPLATE**

## FLORIDA

READY TO ROLL  
Miami  
Phone: (305) 688-8868  
www.readytorolltrains.com  
**O GAUGE, TINPLATE**

## ROUNDHOUSE SOUTH

Port Orange  
Phone: (386) 304-7002  
www.roundhousesouth.com  
**O GAUGE, TINPLATE**

## ILLINOIS

BERWYN'S TOY TRAINS  
Berwyn  
Phone: (708) 484-4384  
www.berwynstoytrains.com  
**O GAUGE**

## MARYLAND

CATOCTIN MTN.  
TRAINS & HOBBIES  
Thurmont  
Phone: (301) 694-8331  
www.cmtrains.com  
**O GAUGE**

ENGINE HOUSE HOBBIES  
Gaithersburg  
Phone: (301) 590-0816  
www.enginehousehobbies.biz  
**O GAUGE**

## SIDETRACK HOBBIES

Leonardtwn  
Phone: (301) 475-5381  
www.sidetrackhobbies.com  
**O GAUGE, TINPLATE**

## TRAIN ROOM

Hagerstown  
Phone: (301) 745-6681  
www.the-train-room.com  
**TINPLATE**

## MASSACHUSETTS

NORTHEAST TRAINS  
Peabody  
Phone: (978) 532-1615  
www.netrains.com  
**O GAUGE**

## NEW JERSEY

THE HOBBY SHOP  
Aberdeen  
Phone: (732) 583-0505  
www.hobbysshopnj.com  
**O GAUGE, TINPLATE**

## NEW YORK

JR JUNCTION TRAIN & HOBBY  
Syracuse  
Phone: (315) 451-6551  
www.jrjunction.com  
**O GAUGE, TINPLATE**

## NASSAU HOBBY

CENTER, INC  
Freeport  
Phone: (516) 378-9594  
www.nassauhobby.com  
**TINPLATE**

## TRAIN WORLD

Brooklyn  
Phone: (718) 436-7072  
www.trainworld.com  
**O GAUGE**

## TRAIN LAND

Lynbrook  
Phone: (516) 599-7080  
www.trainworld.com  
**O GAUGE**

## SCAG'S ELECTRIC

TRAINS  
Staten Island  
Phone: (718) 727-7373  
www.e-zcatch.com  
**O GAUGE, TINPLATE**

## NORTH CAROLINA

TRAIN LOFT  
Winston-Salem  
Phone: (336) 760-9817  
www.trainloft.com  
**O GAUGE**

## OHIO

DIXIE UNION STATION  
Mason  
Phone: (513) 459-0460  
www.dixieunionstation.com  
**O GAUGE**

## GLEN'S TRAINS SHOP

Akron  
Phone: (330) 253-6527  
www.glenstrains.com  
**O GAUGE**

## PENNSYLVANIA

BRADY'S TRAIN  
OUTLET  
Greensburg  
Phone: (724) 838-8448  
www.bradystrainoutlet.com  
**TINPLATE**

## IMPERIAL TRAIN COMPANY

Imperial  
Phone: (724) 695-7552  
www.imperialtrainco.com  
**O GAUGE**

## JIM'S TRAIN SHOP

Homer City  
Phone: (724) 479-2026  
www.jimstrains.com  
**O GAUGE**

## NICHOLAS SMITH

TRAINS  
Broomall  
Phone: (610) 353-8585  
www.nstrains.com  
**O GAUGE, TINPLATE**

## TRAINS R FUN

Frazier  
Phone: (610) 644-4585  
http://www.rccarsfun.com  
**TINPLATE**

## VALLEY FARM MARKET

Weedville  
Phone: (814) 787-8911  
**O GAUGE**

## RHODE ISLAND

B & F HOBBIES  
Wakefield  
Phone: (401) 782-6400  
**O GAUGE, TINPLATE**

## WASHINGTON

EASTSIDE TRAINS  
Kirkland  
Phone: (425) 828-4098  
www.eastsidetrains.com  
**O GAUGE**

Lionel and TMCC-2 Legacy are registered Trademarks of Lionel Trains L.L.C.

© 2008 Caterpillar  
CAT, CATERPILLAR, their respective logos, "Caterpillar Yellow" and the POWER EDGE trade dress, as well as corporate and product identity used herein, are trademarks of Caterpillar and may not be used without permission.

© 2008 Molson Coors Global Properties, LLC.  
Coors trademarks are properties of Molson Coors Global Properties, LLC, used under license by M.T.H. Electric Trains  
Limited Edition Adult Collectible-This licensed product is intended for purchase and enjoyment by individuals of legal purchase age for alcohol beverages.  
The Kilian's trademark is owned by Brasseries Pelforth, S.A.

John Deere is a registered trademark of Deere & Company.

RealTrax® layouts created with RR-Track™ which is a registered trademark of R&S Enterprises.

®/™, M&M'S, the letter M and the M&M'S Characters are registered trademarks of Mars, Incorporated and its affiliates.  
© Mars, Inc. 2008

© 2008 H-D, All Rights Reserved. Manufactured by M.T.H. Electric Trains under license from Harley-Davidson Motor Company.  
© 2008 M.T.H. Electric Trains, 7020 Columbia Gateway Drive, Columbia, Maryland 21046

© 2008 Anheuser-Busch, Inc. All Rights Reserved."

HAWAIIAN PUNCH is a trademark of Dr Pepper/Seven Up, Inc., used by M.T.H. Electric Trains under license. ©2008 Dr Pepper/Seven up, Inc.

DR PEPPER is a trademark of Dr Pepper/Seven Up, Inc., used by M.T.H. Electric Trains under license. ©2008 Dr Pepper/Seven up, Inc.

A&W is a trademark of A&W Concentrate Company, used under license by M.T.H. Electric Trains. ©2008 A&W Concentrate Company

HIRES is a trademark of Dr Pepper/Seven Up, Inc., used by M.T.H. Electric Trains under license. ©2008 Dr Pepper/Seven up, Inc.

7UP is a trademark of Dr Pepper/Seven Up, Inc., used by M.T.H. Electric Trains under license. ©2008 Dr Pepper/Seven up, Inc.

Produced by M.T.H. Electric Trains Under License from Ohio State University

"Products bearing Chicago and North Western, Denver & Rio Grande, MKT, Missouri Pacific, Mo-Pac, Southern Pacific, Texas & Pacific, Union Pacific, Western Pacific are made under trademark license from Union Pacific Railroad Company."

# M.T.H. Online

## GOT QUESTIONS?

WWW.MTHTRAINS.COM HAS ANSWERS

We don't think we're exaggerating when we say M.T.H. has the most useful train manufacturer's site on the Internet. Here's just a sample of the answers you can find online.



**1 WHAT'S THE LATEST INFO ON ...?**

Use Advanced Search to find the latest info on new products before they're delivered—sound sets, cab numbers, feature and paint scheme updates, and other information that arrived after the catalog was published.

**DID YOU EVER MAKE ....?**

Use Advanced Search to search through nearly all of the 14,000 items we've made in the past 28years, for your favorite road name, engine, or type of rolling stock.

**2 DOES ANY DEALER STILL HAVE ...?**

Locate hard-to-find items with our Product Locator, which searches the inventories of M.T.H. dealers across the country.

**3 WHEN IS IT COMING?**

Our online Shipping Schedule is updated frequently to let you know what's coming soon to your hobby shop.

**4 ARE YOU GOING TO MAKE ....?**

View the last several M.T.H. Catalogs online. Or click on Video to see M.T.H. products in action.

**5 HOW CAN I FIX...?**

The Service area of our site allows you to email a question to our factory technicians or find which of our 150+ local service centers is closest to you.

**WHAT REPAIR PART DO I NEED?**

Use Advanced Search to find exploded diagrams and parts lists for M.T.H. locomotives and accessories, and then order the parts online or by phone.

**6 WHAT'S NEW?**

New arrivals and other news are posted frequently on our home page. To get the news as it happens, sign up for our free weekly electronic newsletter, with information on new M.T.H. products, industry news, and sneak peeks at upcoming specials!



**8 HOW DOES IT WORK?**

Misplaced an instruction manual or just want to know how a product works? Use Advanced Search to look up the item and view its instruction manual.

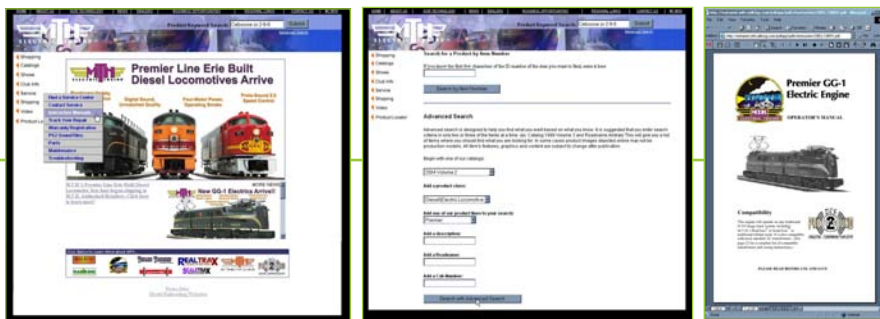

**9 NEWS**

Sign up for our FREE electronic newsletter to stay abreast of the latest M.T.H. News!



**7 HOW CAN I LEARN MORE ABOUT DCS?**

Follow the link to the protosound2.com Web site for DCS and Proto-Sound 2.0 information—and a list of Authorized DCS Demo Centers where you can try DCS hands-on.

**HOW CAN I UPDATE MY DCS SYSTEM OR CHANGE A SOUND SET?**

Only M.T.H. allows you to update your control system or change an engine's sound set right over the Internet. Follow the link to the protosound2.com Web site for DCS and Proto-Sound 2.0 downloads.





# ...SIMPLY THE BEST WAY TO RUN A RAILROAD™



**TRY IT** at your local DCS Demo Center or learn more with a complimentary DVD on DCS & M.T.H. technology.



Take your favorite Proto-Sound® 2.0 Locomotive to any demo center and experience the additional features your engine has with DCS Control.

To Find Your Nearest DCS Demo Center or Request Your Complimentary DVD Visit

# WWW.MTHTRAINS.COM

